

## NC Specifications / FANUC Series

Item		Specification
Controlled axis	Controlled Axes	2 axis(X,Z)
	Max. Simultaneously Controlled Axes	Positioning(G00) / Linear Interpolation(G01) Circular Interpolation(G02, G03)
	Least Input Increment	0.001mm
Spindle Function	Spindle Speed Control	S5 (5 digit)
	Spindle Speed Override	0~120%
	Spindle Orientation	M19
Feed Function	Feedrate Override (10% increase)	0~150%
	Dwell	G04
	Reference Position Return	G27, G28
	Manual Pulse Generator	0.001/0.01/0.1mm
	Dry Run	F0(Fine Feed), 25/50/100%
	Rapid Traverse Override	F0(Fine Feed), 25/50/100%
Tool Functions	Tool Number Command	T2(2 Digit), T4(Digit)
	Tool nose radius compensation	G40 ~ G42
	Tool offset pair	128EA
	Tool geometry/wear offset	GEOMETRY & WEAR DATA
Programming Function	Canned Cycle	G70~G72, G74~G76
	Decimal Point Input	Able to input up to decimal point
	Sub Program	4Phase
	Work Coordinate System	G52~G59
	Max Program Dimension	±99999.999mm
Tape Functions	M Function	M3(3 Digit)
	Input Code	ISO/EIA Auto Recognition
	I/O Interface	RS232C
	rogram Storage Space	1280M(512kb)
	Number of stored programs	400EA
Other Functions	Display Unit / MDI	10.4" color LCD / Soft input type MDI
	Synchronized Tapping	Rigid Tapping Function
	Background Tapping	Program saving/editing during automatic operation
	Backlash Compensation	Pitch Error Offset Compensation for Each Axis
	Search Function	Sequence / program number search
	Safety Function	Emergency stop / overtravel
	Program Test Function	Machine Lock / Single Block
	Control Function	Memory / MDI / Manual
	Mirror Image	
	Run hour and parts count display	
	Custom Macro	#100 ~ #199, #500 ~ #999

# SMEC

## SL 4500 series

### HORIZONTAL TURNING CENTER



**SMEC**  
SMEC CO.,LTD.

**SMEC Co., Ltd.**  
157-10, Goldenroot-ro, Juchon-myeon,  
Gimhae-si, Gyeongsangnam-do, Korea  
Tel +82 55 340 4800  
Fax +82 55 340 4740



**SMEC**  
Smart One,  
Global One

**SMEC**  
SMEC CO.,LTD.

- 1988 - Started as Samsung Heavy Industries Machine Tools Business
- 1989 - Horizontal and vertical machining center technology partnership with OKK Japan
- 1991 - Turning center and vertical machining center technology partnership with Mori Seiki
- 1996 - 5-sided processing center technology partnership with Toshiba
- 1999 - Spun out from Samsung Aerospace Industries and established SMEC Co., Ltd

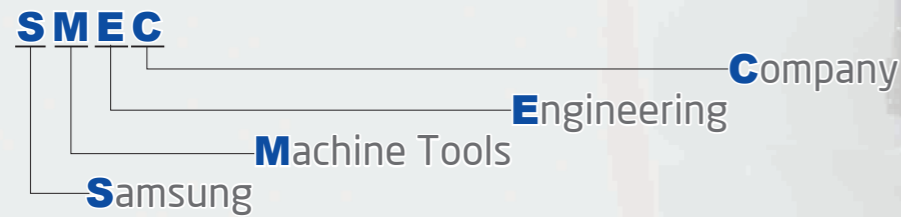

## SL 4500/4500X/4500L/4500XL

- A Type : 18(15)"
- B Type : 21"
- C Type : 24"

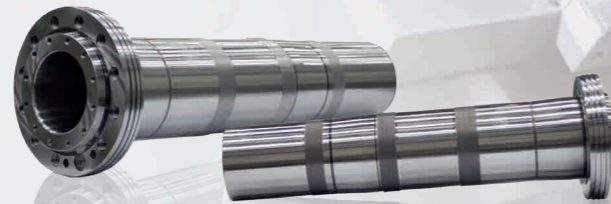

Strongest in its class with superb structural design  
Simultaneous heavy duty and precision turning

- 45 degree torque tube type bed to support heavy duty turning
- Significantly reduced non-cutting time and efficient turning
- Low-center of gravity reducing vibration, thermal deformation and improving rigidity

## High Accuracy, High Rigidity Spindle

### Pin Tube Rib Design for Minimal Axis Heat Transfer

Radiator fan-like pin tube rib design dissipates heat generated by axis movements, maintaining minimal thermal expansion.

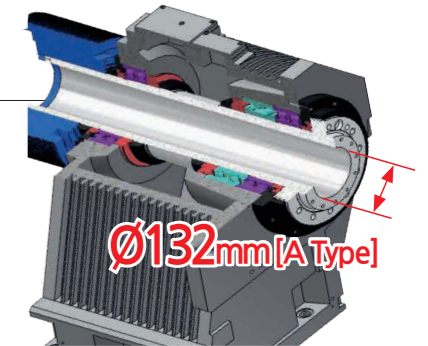
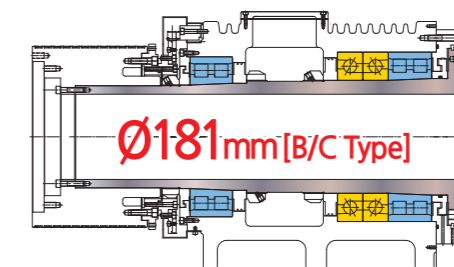

### Output Converting Transmission

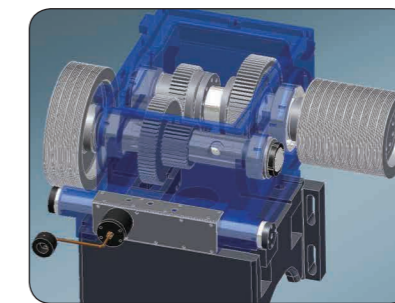

Equipped as standard feature, high Output Converting Transmission provides heavy-duty machining.

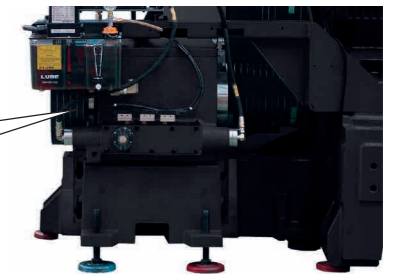

### Spindle Power & Torque Diagram

SL 4500/4500M(A Type)

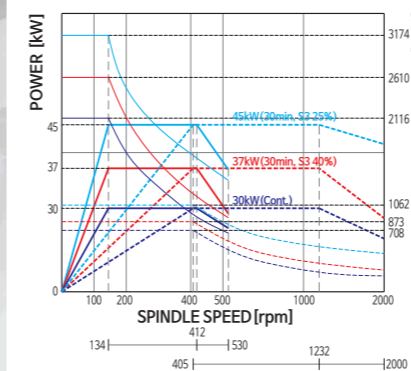

SL 4500/4500M (B Type)

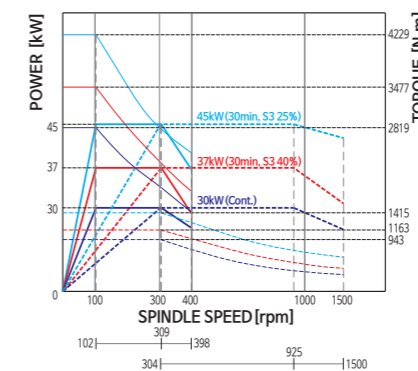

SL 4500/4500M (C Type)

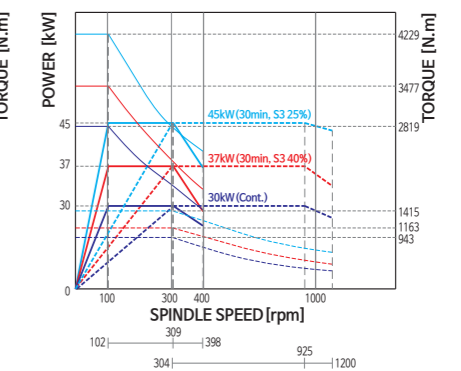



An innovative high precision, heavy duty CNC Lathe,  
integrated with all of SMEC's advanced technology  
- **SL 4500 series**

Spindle speed  
**2,000 rpm** (A Type 15")  
**1,800 rpm** (A Type 18")  
**1,500 rpm** (B Type 21")  
**1,200 rpm** (C Type 24")

Max. machining length  
**1,250 mm** (SL 4500)    **1,213 mm** (SL 4500M)  
**2,255 mm** (SL 4500X)    **2,255 mm** (SL 4500XM)  
**3,055 mm** (SL 4500L)    **3,055 mm** (SL 4500LM)

Spindle motor(cont./max.)  
**30/45 kW**

Feed motor(X/Z)  
**7/6 kW**

Rapid traverse(X/Z)  
**20/20 m/min** (SL4500/M)  
**20/18 m/min** (SL4500X/XM)  
**20/10 m/min** (SL4500L/LM)

Max. machining diameter  
**Ø690 mm** (STD Turret)  
**Ø620 mm** (Mill Turret)

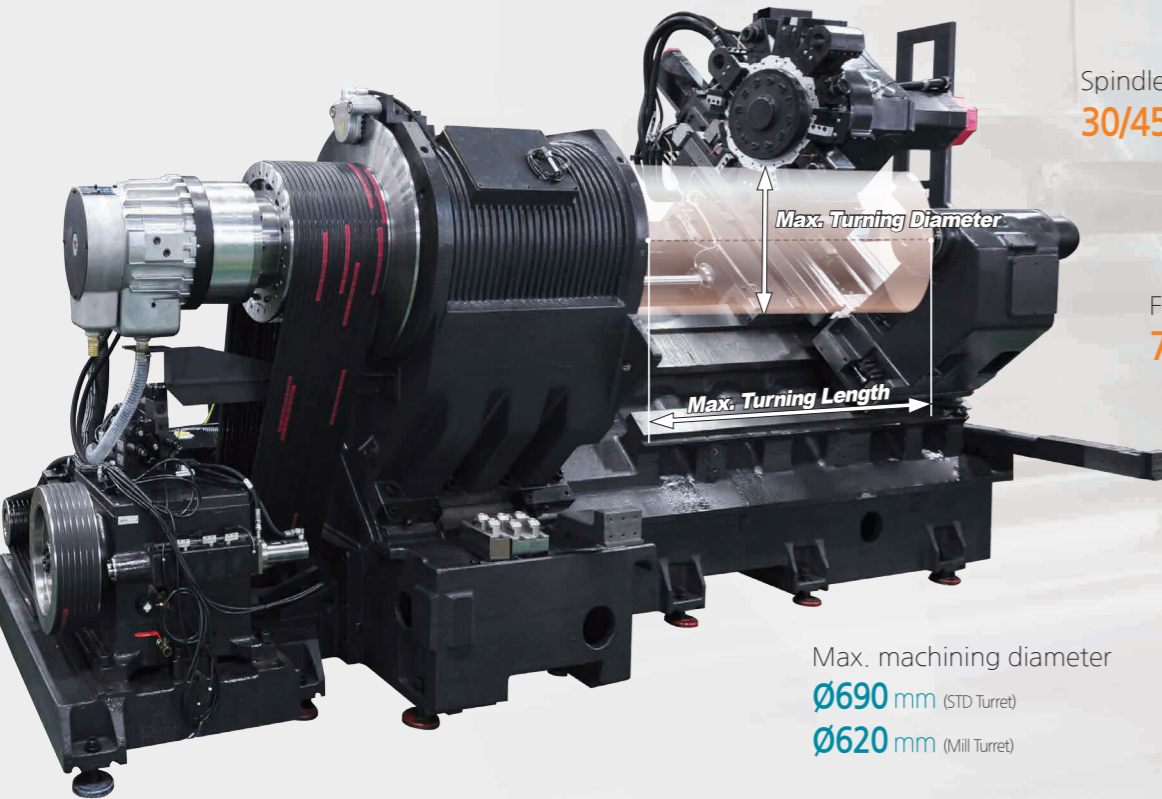

**Highly Reliable and Rigid Structural Design**

- One piece Meehanite casting with heavily ribbed torque tube design
- Rigid bed supports for powerful cutting
- Excellent vibration dampening and thermal displacement design

**SL 4500 (High Speed Hydraulic Turret)**

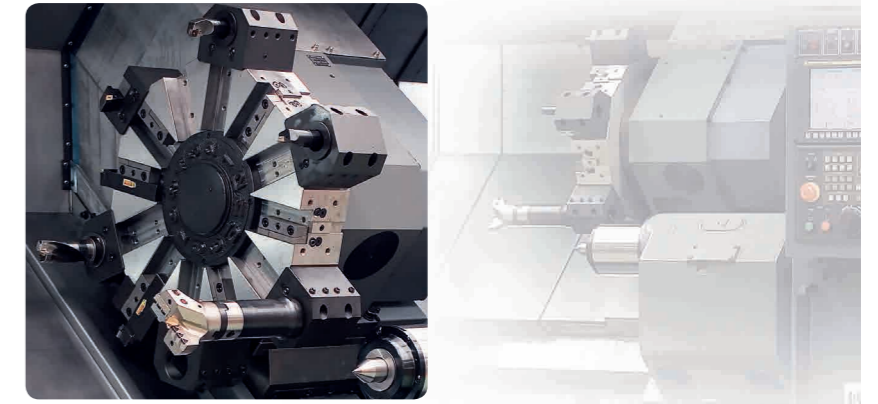

Indexing Time  
**0.2 sec(60 Hz)**    Number of tool positions  
**Std : 12 / Opt : 10 stations**

**High Speed, Heavy Duty Hyd. Index Turret**

Driven by a high torque hydraulic index motor, the 10-station heavy-duty turret can accept tools on both left and right side of each station. Turret indexing (repeatability ± 0.005) is non-stop, bi-directional with a fast 0.25 second next station index time. A large diameter (Ø250) Curvic coupling with 6,377kgf clamping force enables precision as well as heavy-duty cutting.

**SL 4500M (BMT High Speed Turret)**

**Turret Torque Diagram(BMT75)**

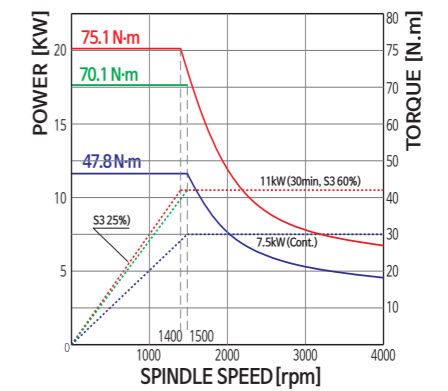

Indexing Time  
**0.2 sec(60 Hz)**    Number of tool positions  
**12 stations**    Milling Spindle Speed  
**4,000 rpm**    Tool Holder  
**BMT 75**

**BMT Milling Turret (M Type)**

SL4500 Milling type is equipped with standard 12-station BMT turret capable of accepting rotary tools at any station, providing flexible machining thru various machining operations in just one set-up. Each BMT holder is securely tightened by 4 screws, allowing the turret to perform heavy-duty cutting, milling and drilling operations. Turret indexing is non-stop, bi-directional with a fast 0.25second next station index time.



### Centralized Operation Panel

The centralized operation panel with its 10.4 inch color TFT LCD monitor is able to swivel 90 degrees, providing operators with easy access to the control panel while working on the machine.

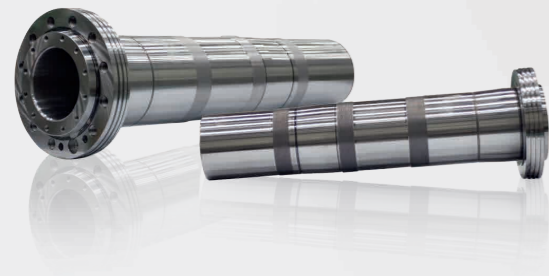

### Rigid 45 degree Slant Bed

45 degree slant torque tube design bed and wide guide slide way ensure long term rigidity and machining accuracy. Also, the Slant Type structure allows easier access to the workpiece and superb chip discharge.

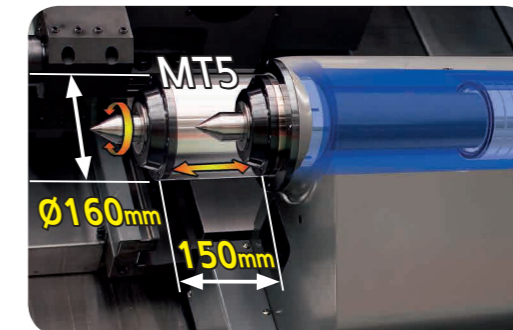
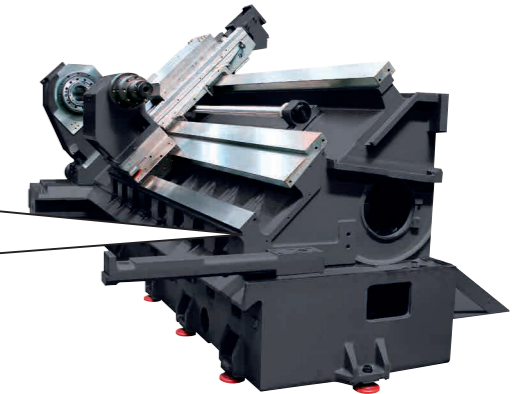
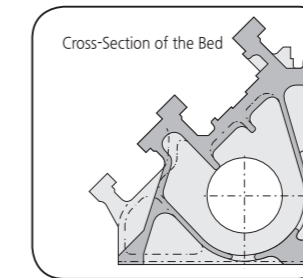

### Programmable Tailstock (Carriage direct-coupled) [Std.]

The programmable tailstock body mounted is on wide guide ways to ensure rigid work piece support.

### Pre-tensioned and Double Anchored Ballscrews

All axes ballscrews are pre-tensioned, heat treated and fixed by double anchors on both ends, providing ultimate rigidity and minimal thermal growth.

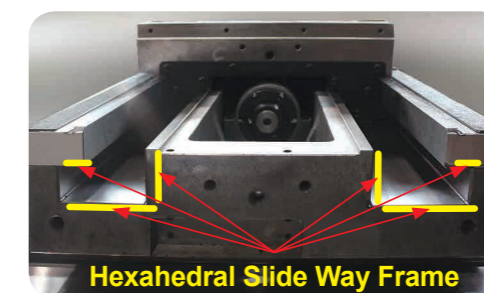
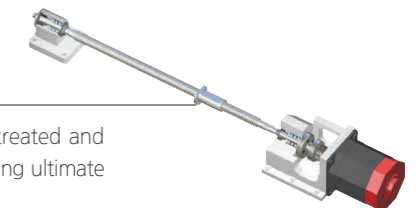

### Hexahedral Slide Way Frame (X-axis)

Wide integral way is machined from the casting, induction hardened and precision ground to ensure long-term rigidity, machining accuracy and heavy-duty machining.





Work Range

Unit : mm

**STD Turret**

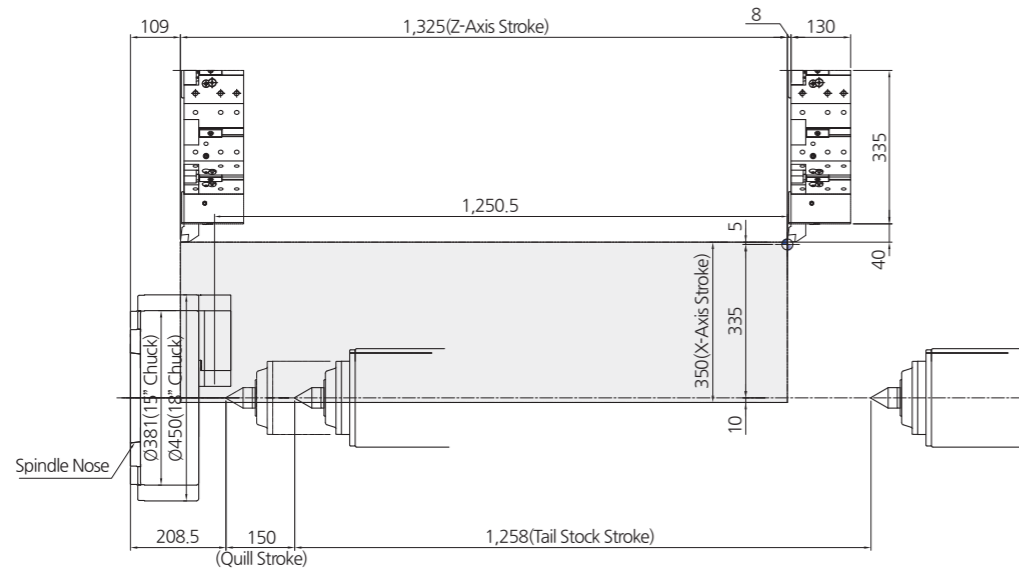

**Mill Turret (BMT 75)**

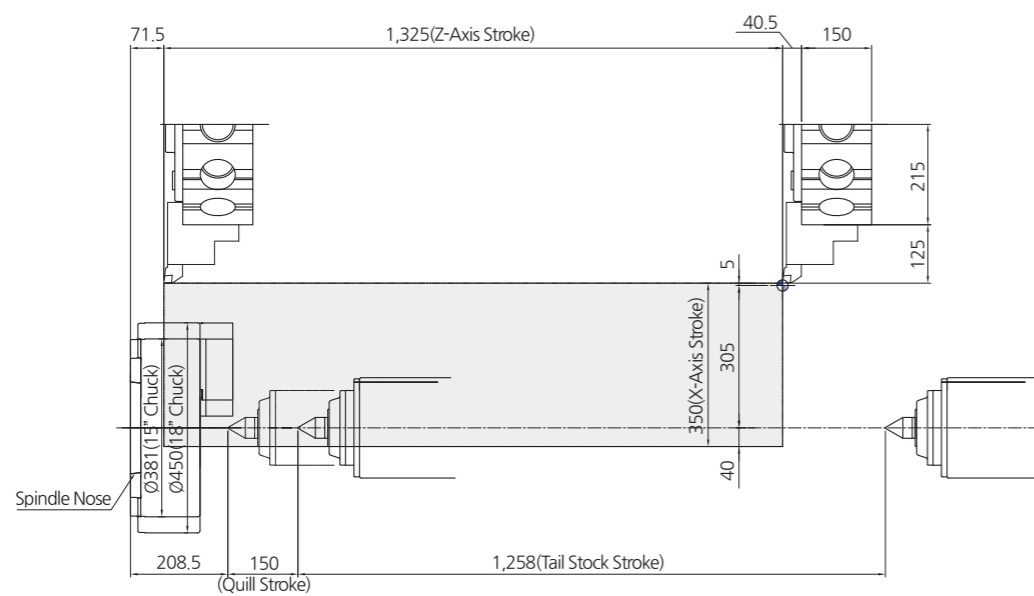

Turret Head Interference

Unit : mm

**STD Turret**

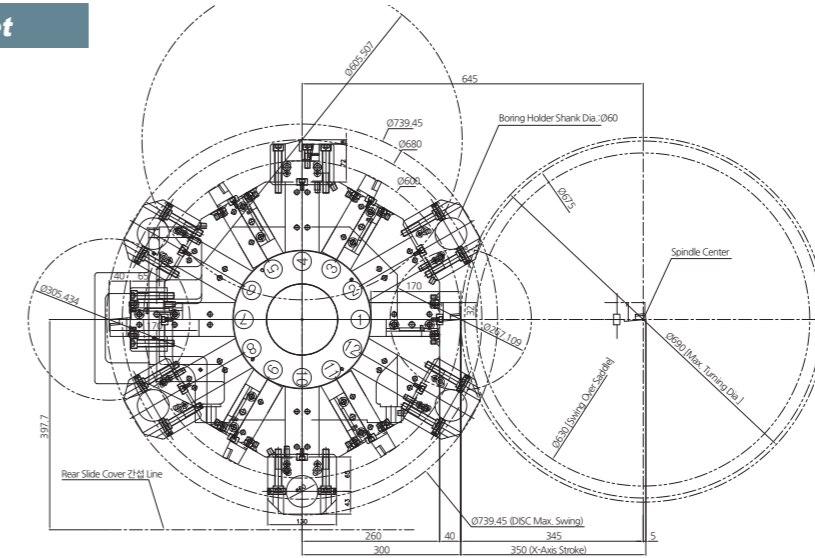

**Mill Turret (BMT 75)**

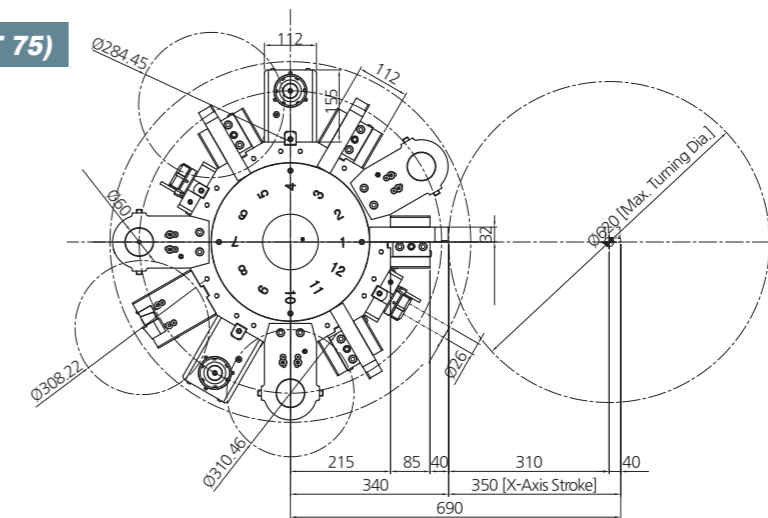

**Standard Accessories**

- 15" hollow 3 jaws chuck (A Type)
- 18" hollow 3 jaws chuck (A Type)
- 21" hollow 3 jaws chuck (B Type)
- 24" hollow 3 jaws chuck (C Type)
- Chuck clamp confirmation
- Chuck clamp foot switch
- Chuck pressure switch
- Coolant system
- Door interlock
- Full splash guard with coolant tank

- Jaw (soft 3set, hard 1set)
- Leveling unit
- Main spindle orientation
- Manual/Part list (1set)
- Patrol lamp (3 colors)
- Safety precaution name plate
- Tailstock (programmable)
- Tool box
- Tool holders
- Work light (LED lamp)

**Optional Accessories**

- Air blower
- Air conditioners (electric cabinet)
- Air gun
- Auto door
- Bar Feeder Interface
- Chip bucket
- Chip conveyor
- Coolant blower
- Coolant chiller
- Coolant gun
- Coolant level switch
- Counter (total, multi, tool, work)
- Dual pressure chucking
- Oil mist collector
- Oil skimmer
- Robot interface
- Special chuck
- Steady rest (single, dual)
- Tool presetter (manual/auto)
- Transformer

Machine Dimensions

Unit : mm

**SL 4500**

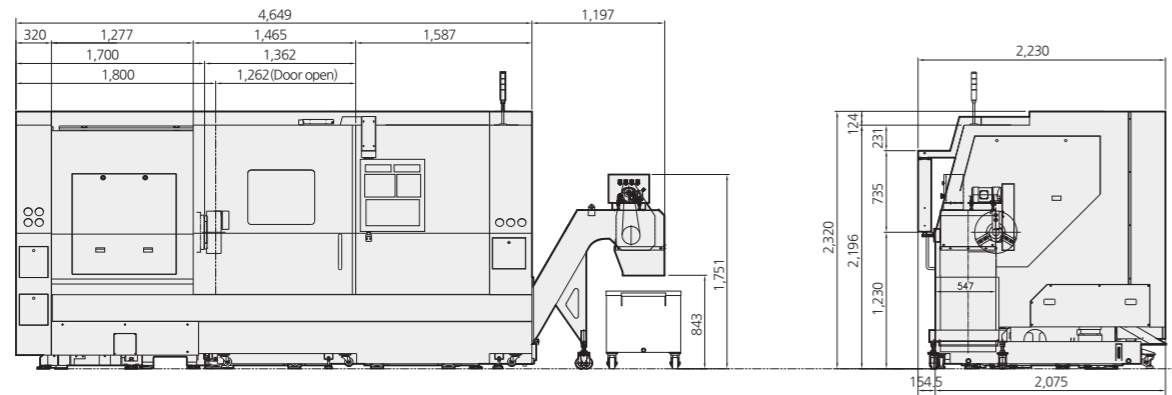

**SL 4500X**

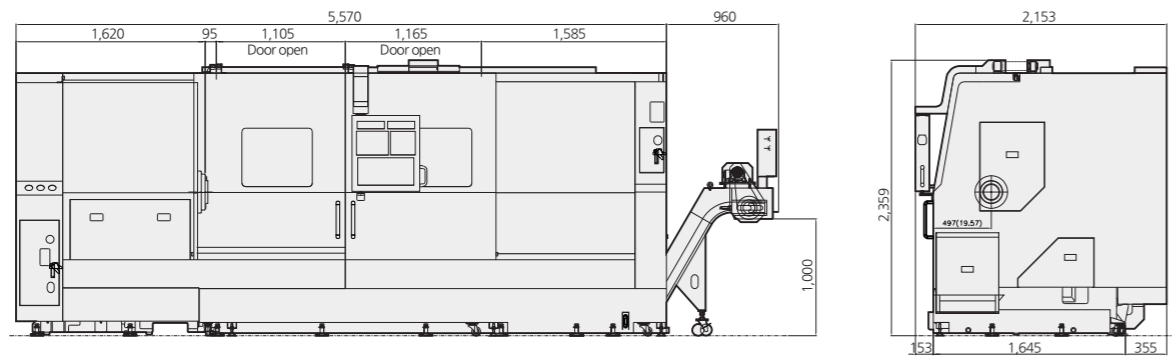

**SL 4500L**

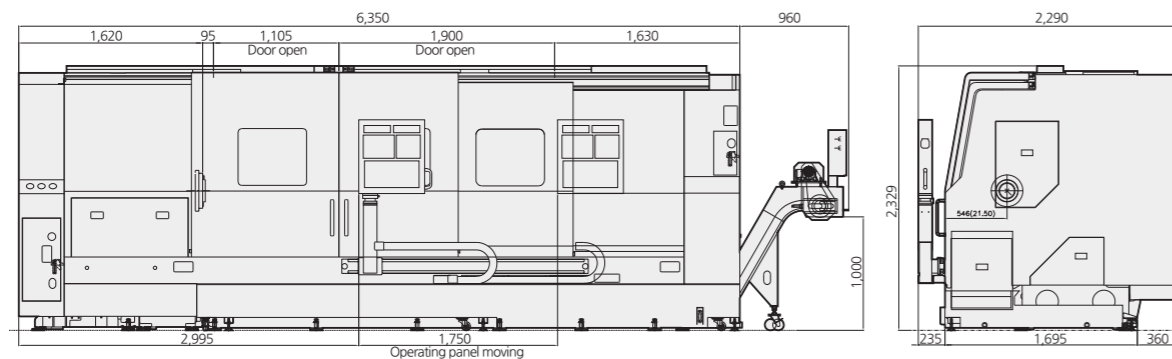

Major Specifications

DESCRIPTION			SL 4500			SL 4500M		
			A type	B type	C type	A type	B type	C type
Chuck	Chuck size	inch	18[15]"	21"	24"	18[15]"	21"	24"
	Swing over bed	mm	775	775	775	775	775	775
Capacity	Swing over cross slide	mm	630	630	630	630	630	630
	Max. turning diameter	mm	690	690	690	620	620	620
	Max. milling diameter	mm	-	-	-	712	712	712
	Max. machining length	mm	1,250	1,250	1,250	1,213	1,213	1,213
Spindle	Spindle speed	rpm	1,800[2,000]	1,500	1,200	1,800[2,000]	1,500	1,200
	Spindle nose	ASA	A2-11	A2-15	A2-15	A2-11	A2-15	A2-15
	Draw tube ID	mm	117.5	140	166.5	117.5	140	166.5
	Spindle bore diameter	mm	132	181	181	132	181	181
	Motor (Cont./Max)	kW	30/45	30/45	30/45	30/45	30/45	30/45
Travels	X-axis travel	mm	350	350	350	350	350	350
	Z-axis travel	mm	1,325	1,325	1,325	1,325	1,325	1,325
	X-axis Rapid travers rate	m/min	20	20	20	20	20	20
	Z-axis Rapid travers rate	m/min	20	20	20	20	20	20
Turret	Number of tool stations	ea	12[10]	12[10]	12[10]	12 (BMT75)	12 (BMT75)	12 (BMT75)
	Turning tool shank size	mm	32	32	32	32	32	32
	Boring bar diameter	mm	60	60	60	60	60	60
	Turret index time(next station swivel time)	sec	0.20	0.20	0.20	0.20	0.20	0.20
	Rotary tool speed	rpm	-	-	-	4,000	4,000	4,000
	Rotary tool motor (Cont./Max)	kW	-	-	-	5.5/7.5	5.5/7.5	5.5/7.5
Tailstock	Quill diameter	mm	160	160	160	160	160	160
	Quill stroke	mm	150	150	150	150	150	150
	Spindle taper	MT	MT5 (Built-in)	MT5 (Built-in)	MT5 (Built-in)	MT5 (Built-in)	MT5 (Built-in)	MT5 (Built-in)
Machine	Size (with Side Chip conveyor) LxWxH	mm	4,649(5,846) × 2,230 × 2,320			4,649(5,846) × 2,230 × 2,320		
	Size (with Rear Chip conveyor) LxWxH	mm	-			-		
	weight	kg	10,000	11,000	11,000	10,500	11,500	11,500
	Coolant tank capacity	Liter	351	351	351	351	351	351
ELECTRIC POWER SUPPLY	kVA/V	62/220	62/220	62/220	71/220	71/220	71/220	
CONTROLLER		FANUC, SIEMENS						

※Figures in inches are converted from metric measurements.

**Major Specifications**

DESCRIPTION			SL 4500X			SL 4500XM		
			A type	B type	C type	A type	B type	C type
Chuck	Chuck size	inch	18[15]"	21"	24"	18[15]"	21"	24"
Capacity	Swing over bed	mm	775	775	775	775	775	775
	Swing over cross slide	mm	630	630	630	630	630	630
	Max. turning diameter	mm	690	690	690	620	620	620
	Max. milling diameter	mm	-	-	-	712	712	712
	Max. machining length	mm	2,255	2,255	2,255	2,255	2,255	2,255
Spindle	Spindle speed	rpm	1,800[2,000]	1,500	1,200	1,800[2,000]	1,500	1,200
	Spindle nose	ASA	A2-11	A2-15	A2-15	A2-11	A2-15	A2-15
	Draw tube ID	mm	117.5	140	166.5	117.5	140	166.5
	Spindle bore diameter	mm	132	181	181	132	181	181
	Motor (Cont./Max)	kW	30/45	30/45	30/45	30/45	30/45	30/45
Travels	X-axis travel	mm	350	350	350	350	350	350
	Z-axis travel	mm	2,330	2,330	2,330	2,330	2,330	2,330
	X-axis Rapid travers rate	m/min	20	20	20	20	20	20
	Z-axis Rapid travers rate	m/min	18	18	18	18	18	18
Turret	Number of tool stations	ea	12	12	12	12 (BMT75)	12 (BMT75)	12 (BMT75)
	Turning tool shank size	mm	32	32	32	32	32	32
	Boring bar diameter	mm	60	60	60	60	60	60
	Turret index time(next station swivel time)	sec	0.20	0.20	0.20	0.20	0.20	0.20
	Rotary tool speed	rpm	-	-	-	4,000	4,000	4,000
	Rotary tool motor (Cont./Max)	kW	-	-	-	5.5/7.5	5.5/7.5	5.5/7.5
Tailstock	Quill diameter	mm	160	160	160	160	160	160
	Quill stroke	mm	150	150	150	150	150	150
	Spindle taper	MT	MT5 (Built-in)	MT5 (Built-in)	MT5 (Built-in)	MT5 (Built-in)	MT5 (Built-in)	MT5 (Built-in)
Machine	Size (with Side Chip conveyor) LxWxH	mm	5,570(6,530) × 2,153 × 2,359			5,570(6,530) × 2,153 × 2,359		
	Size (with Rear Chip conveyor) LxWxH	mm	-			-		
	weight	kg	13,000	13,000	13,000	13,000	13,000	13,000
	Coolant tank capacity	Liter	400	400	400	400	400	400
ELECTRIC POWER SUPPLY	kVA/V	59/220	59/220	59/220	60/220	60/220	60/220	
CONTROLLER		FANUC, SIEMENS						

※Figures in inches are converted from metric measurements.

**Major Specifications**

DESCRIPTION			SL 4500L			SL 4500LM		
			A type	B type	C type	A type	B type	C type
Chuck	Chuck size	inch	18[15]"	21"	24"	18[15]"	21"	24"
Capacity	Swing over bed	mm	775	775	775	775	775	775
	Swing over cross slide	mm	630	630	630	630	630	630
	Max. turning diameter	mm	690	690	690	620	620	620
	Max. milling diameter	mm	-	-	-	712	712	712
	Max. machining length	mm	3,055	3,055	3,055	3,055	3,055	3,055
Spindle	Spindle speed	rpm	1,800[2,000]	1,500	1,200	1,800[2,000]	1,500	1,200
	Spindle nose	ASA	A2-11	A2-15	A2-15	A2-11	A2-15	A2-15
	Draw tube ID	mm	117.5	140	166.5	117.5	140	166.5
	Spindle bore diameter	mm	132	181	181	132	181	181
	Motor (Cont./Max)	kW	30/45	30/45	30/45	30/45	30/45	30/45
Travels	X-axis travel	mm	350	350	350	350	350	350
	Z-axis travel	mm	3,130	3,130	3,130	3,130	3,130	3,130
	X-axis Rapid travers rate	m/min	20	20	20	20	20	20
	Z-axis Rapid travers rate	m/min	10	10	10	10	10	10
Turret	Number of tool stations	ea	12	12	12	12 (BMT75)	12 (BMT75)	12 (BMT75)
	Turning tool shank size	mm	32	32	32	32	32	32
	Boring bar diameter	mm	60	60	60	60	60	60
	Turret index time(next station swivel time)	sec	0.20	0.20	0.20	0.20	0.20	0.20
	Rotary tool speed	rpm	-	-	-	4,000	4,000	4,000
	Rotary tool motor (Cont./Max)	kW	-	-	-	5.5/7.5	5.5/7.5	5.5/7.5
Tailstock	Quill diameter	mm	160	160	160	160	160	160
	Quill stroke	mm	150	150	150	150	150	150
	Spindle taper	MT	MT5 (Built-in)	MT5 (Built-in)	MT5 (Built-in)	MT5 (Built-in)	MT5 (Built-in)	MT5 (Built-in)
Machine	Size (with Side Chip conveyor) LxWxH	mm	6,350(7,310) × 2,290 × 2,329			6,350(7,310) × 2,290 × 2,329		
	Size (with Rear Chip conveyor) LxWxH	mm	-			-		
	weight	kg	20,000	20,000	20,000	20,000	20,000	20,000
	Coolant tank capacity	Liter	600	600	600	600	600	600
ELECTRIC POWER SUPPLY	kVA/V	59/220	59/220	59/220	60/220	60/220	60/220	
CONTROLLER		FANUC, SIEMENS						

※Figures in inches are converted from metric measurements.