

SMEC

SL 2500/3000 series

CNC TURNING CENTER



SMEC
SMEC CO.,LTD.

SMEC Co., Ltd.

157-10, Goldenroot-ro, Juchon-myeon, Gimhae-si, Gyeongsangnam-do, Korea

Tel +82 55 340 4800 Fax +82 55 340 4740

<http://www.esmec.com>



◆ Design and specifications subject to change without notice.

© SMEC 2017.07-NO.1

SMEC
SMEC CO.,LTD.

- 1988 - Started as Samsung Heavy Industries Machine Tools Business
- 1989 - Horizontal and vertical machining center technology partnership with OKK Japan
- 1991 - Turning center and vertical machining center technology partnership with Mori Seiki
- 1996 - 5-sided processing center technology partnership with Toshiba
- 1999 - Spun out from Samsung Aerospace Industries and established SMEC Co., Ltd

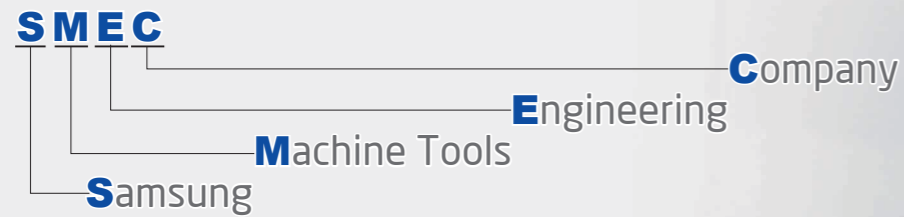

SL 2500 series

SL 2500A, SL 2500AM, SL 2500B, SL 2500BM
 SL 2500AX, SL 2500AXM, SL 2500BX, SL 2500BXM
 SL 2500AL, SL 2500ALM, SL 2500BL, SL 2500BLM

SL 3000 series

SL 3000A, SL 3000AM, SL 3000B, SL 3000BM
 SL 3000AX, SL 3000AXM, SL 3000BX, SL 3000BXM
 SL 3000AL, SL 3000ALM, SL 3000BL, SL 3000BLM

Strongest in class with superb structural design
Simultaneous heavy duty and precision turning

- 45 degree torque tube type bed to support heavy duty turning
- Significantly reduced non-cutting time and efficient turning
- Low-center of gravity reducing vibration, thermal deformation and improving rigidity

High Accuracy, High Rigidity Spindle

Pin Tube Rib Design for Minimal Thermal Deformation

Radiator fan-like pin tube rib design dissipates heat generated by axis movements, maintaining minimal thermal expansion.



C-Axis

With C-axis control, users get synchronized control on 3axes which enables integrated processing, such as milling, drilling & rigid tapping.

SPINDLE & HEADSTOCK

The Spindle and Headstock are machined in a temperature controlled environment and assembled in a clean room.

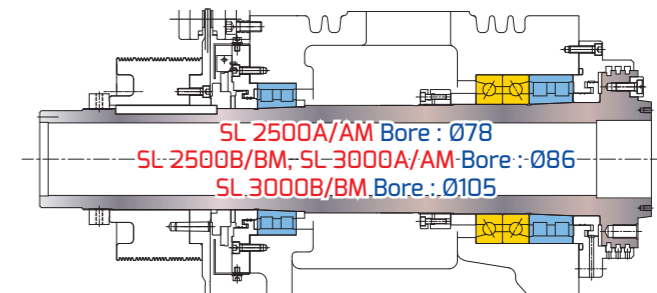

Precision double row cylindrical roller bearings and angular contact ball bearings are located at the front of the spindle, and a double row of cylindrical roller bearings is located in the rear to ensure heavy cutting capabilities with precision.

Spindle Power & Torque Diagram

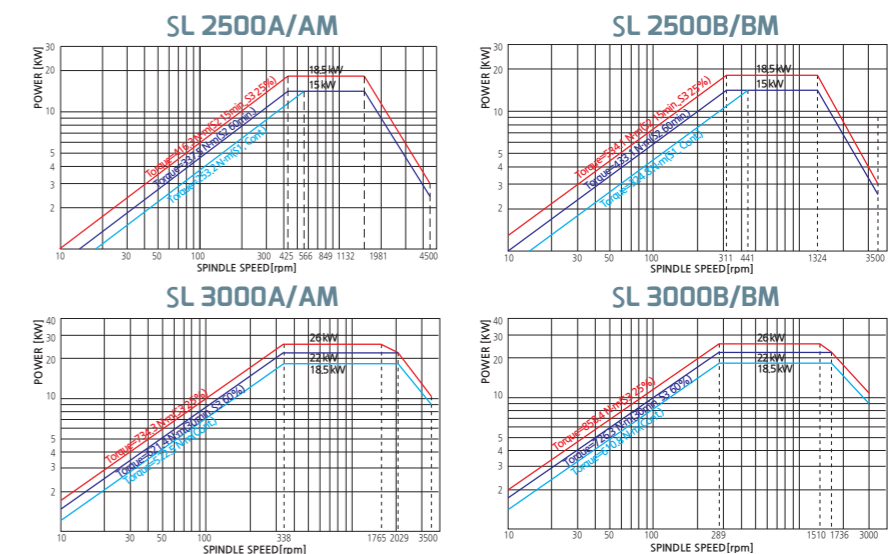

An innovative high precision, heavy duty CNC Lathe, integrated with all of SMEC's advanced technology - SL 2500/3000 series

Spindle motor(Max./Cont.)

18.5/15 kW (SL 2500 series)

26/18.5 kW (SL 3000 series)

Spindle speed

4,500 rpm (SL 2500A/AM/AX/AXM/AL/ALM)

3,500 rpm (SL 2500B/BM/BX/BXM/BL/BLM/
SL 3000A/AM/AX/AXM/AL/ALM)

3,000 rpm (SL 3000B/BM/BX/BXM/BL/BLM)

Rapid traverse(X/Z)

24/30 m/min

Bar working diameter

67 mm (SL 2500A/AM/AX/AXM/AL/ALM)

76 mm (SL 2500B/BM/BX/BXM/BL/BLM)
(SL 3000A/AM/AX/AXM/AL/ALM)

90 mm (SL 3000B/BM/BX/BXM/BL/BLM)

Max. machining diameter

Ø430 mm (SL 2500A/B/AX/BX/AL/BL
SL 3000A/B/AX/BX/AL/BL)

Ø405 mm (SL 2500AM/BMAXM/BXM/ALM/BLM
SL 3000AM/BMAXM/BXM/ALM/BLM)

Highly Reliable and Rigid Structural Design

- One piece Meehanite casting with heavily ribbed torque tube design
- Rigid bed supports for powerful cutting
- Excellent vibration dampening and thermal displacement design

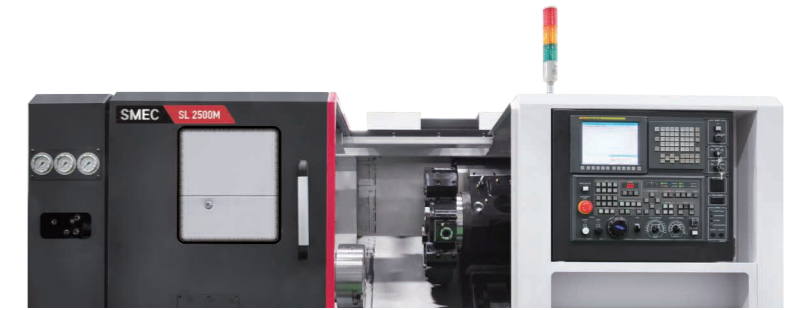

SL 2500/3000 A/B/AX/BX/AL/BL

High Speed, Heavy Duty Hyd. Index Turret

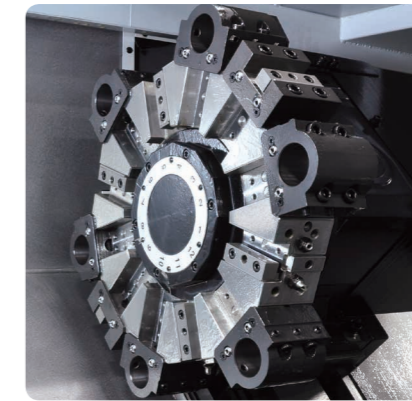

Indexing Time

0.2sec (60Hz)

Non-Cutting Time Significantly Reduced with Installation of High Speed Turret with 0.2 Sec Indexing Time

A 0.2 second 1 station indexing time is made possible by employing the Nonstop Random Index method using the SMEC developed high-power Servo Index Motor.

The Ø179mm large diameter Curvic Coupling significantly improves the clamping power and indexing precision.

Number of tool positions

12stations

SL 2500/3000 AM/BM/AXM/BXM/ALM/BLM

High Speed Servo Turret (Tool Holder BMT65)

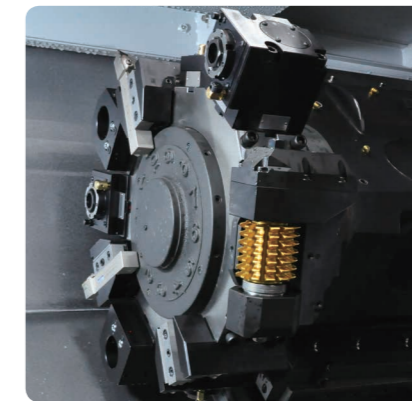

Turret Torque Diagram

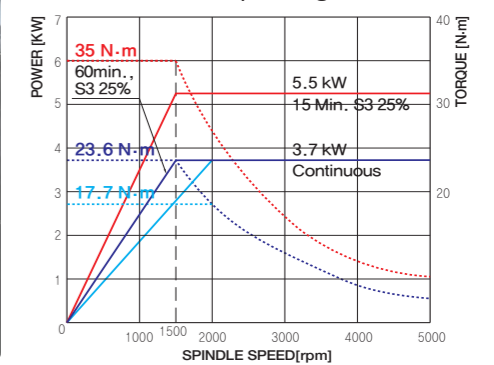

Easier HYD Valve Control

The gauge and control valve for HYD valve is raised to the operator's eye-level making maintenance easier.

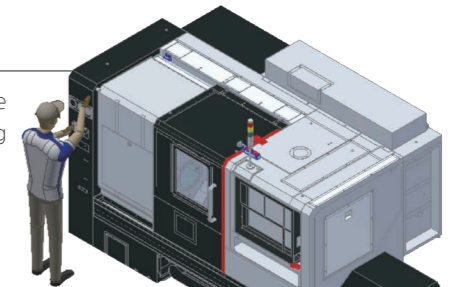

Easier Coolant Tank Cleaning

Cleaning the coolant tank is made easier with a coolant tank that can be removed while leaving the chip conveyor bolted to the machine. (AL/ALM/BL/BLM Series not included)

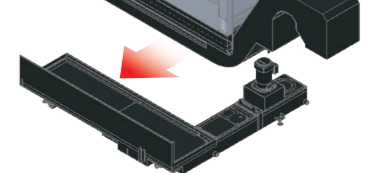

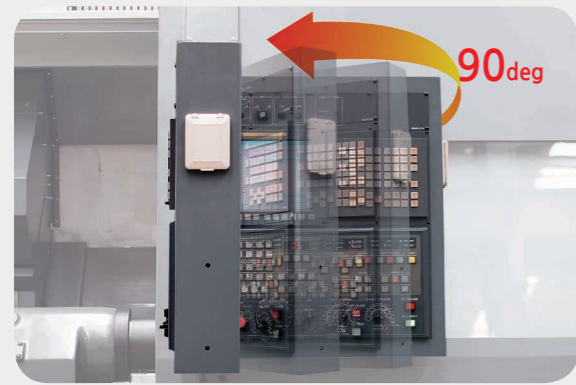

Centralized Operation Panel

The centralized operation panel with its 10.4 inch color TFT LCD monitor is able to swivel 90 degrees, providing operators with easy access to the control panel while working on the machine.



Rigid 45 degree Slant Bed

45 degree slant torque tube design bed and wide guide slide way ensure long term rigidity and machining accuracy.

Also, the Slant Type structure allows for easier access to the workpiece and superb chip discharge.

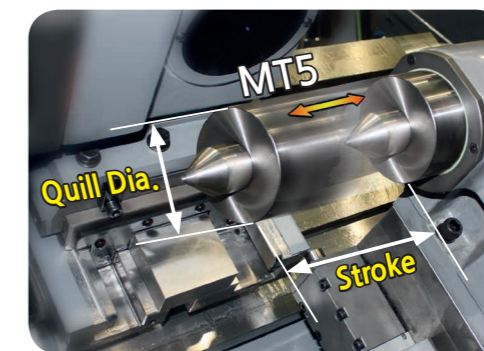
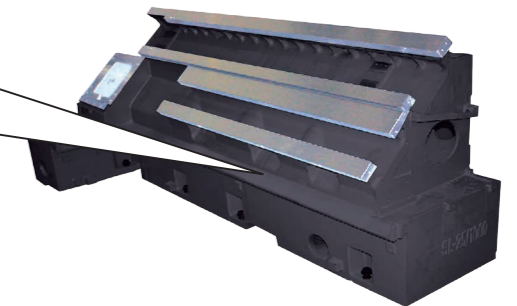
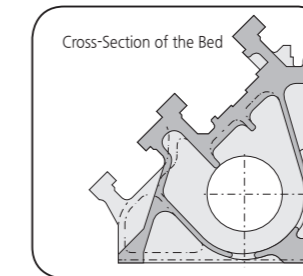

Programmable Tailstock

The tailstock that maintains superb high precision during heavy duty cutting can be manually traversed using the MPG handle. Also, when the programmable tailstock option is mounted, the tailstock and quill may be operated back and forth automatically using M-codes. (SL2500M/SL3000M : Std.)

Model	Quill Diameter	Stroke
SL 2500/3000 A/B Sseries(Programable)	Ø85(110)mm	80(100)mm
SL 2500/3000 AM/BM Series(Programable)	Ø85(110)mm	80(100)mm
SL 2500/3000 AX/AXM/BX/BXM Series	Ø110mm	100mm
SL 2500/3000 AL/ALM/BL/BLM Series	Ø110mm	100mm

Pre-tensioned and Double Anchored Ballscrews

All axes ballscrews are pre-tensioned, heat treated and fixed by double anchors on both ends, providing ultimate rigidity and minimal thermal growth.

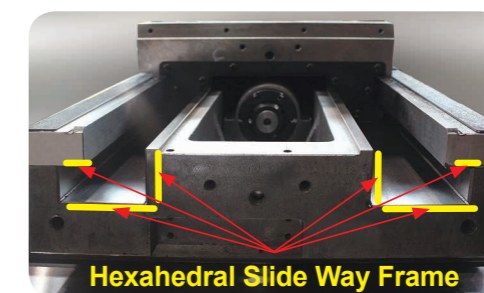
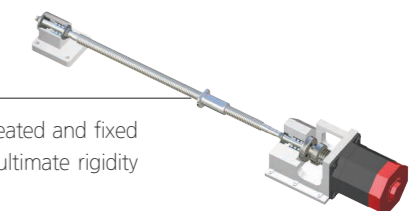

Hexahedral Slide Way Frame (X-axis)

Wide integral way is machined from the casting, induction hardened and precision ground to ensure long-term rigidity, machining accuracy and heavy-duty machining.

High Precision

Surface Roughness

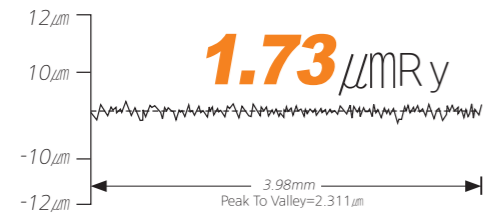

Model : SL 2500M

Roundness

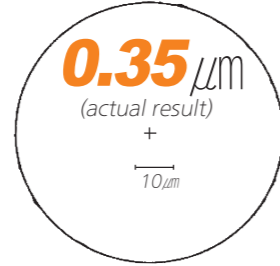

Cutting condition	
Tool	Diamond tool <nose radius 0.020 inch>
Material	AL150<Aluminum>
Cutting speed	230 m/min
Feedrate	0.05 mm/rev
Depth of cut	0.1 mm
Outer diameter	200 mm
Filter	1-50

Processing Speed

Turning Performance (material:SM45C) SL 2500A

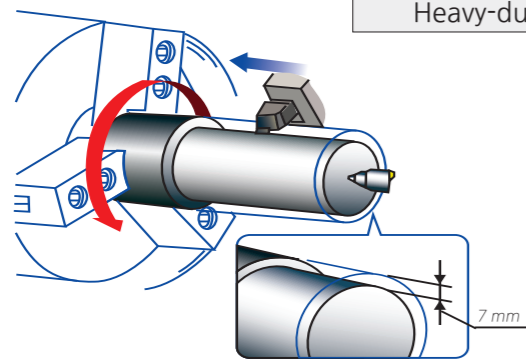

Heavy-duty cutting (O.D) <25mm×25mm qualified tool>

Spindle speed
524 rpm
Cutting speed
250m/min
Depth of cut
4 mm <Spindle Load 50%>
Feedrate
0.4 mm/rev

Optional Accessories

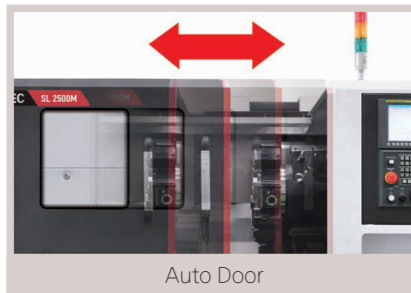
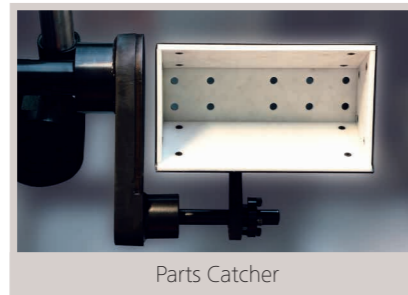

Tooling System

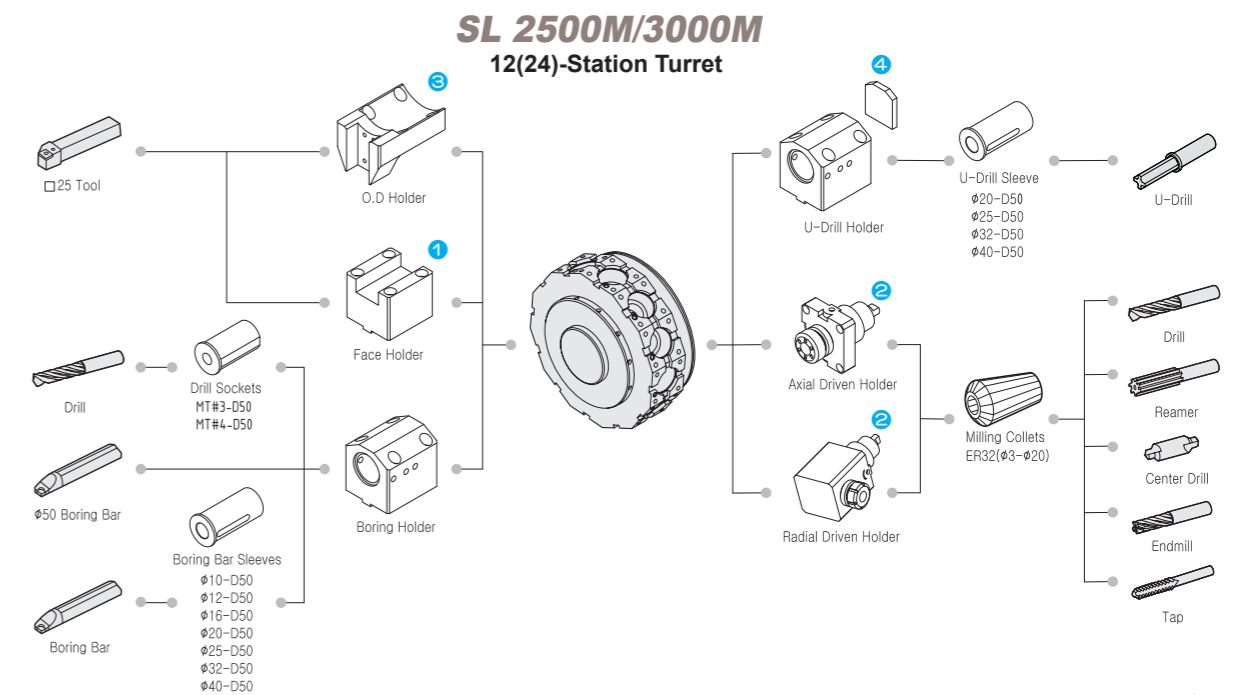
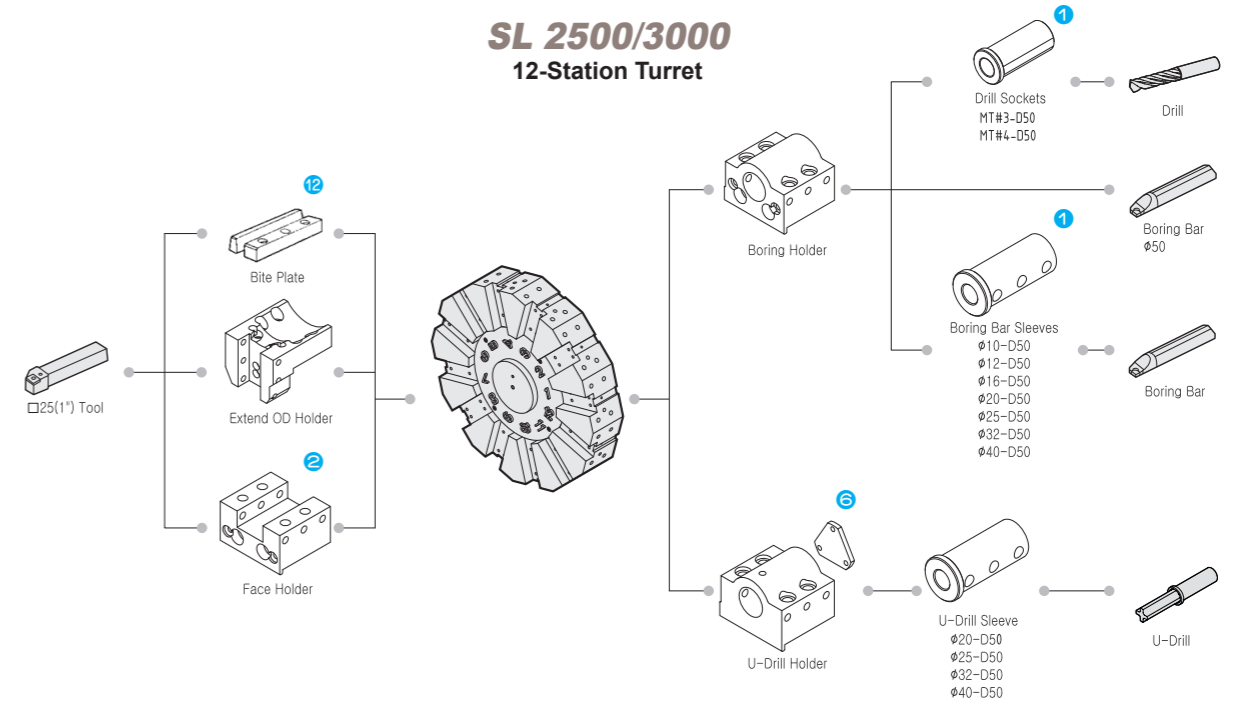

● : Standard Set Numbers

Machine Dimensions

Unit : mm

SL 2500/3000 series

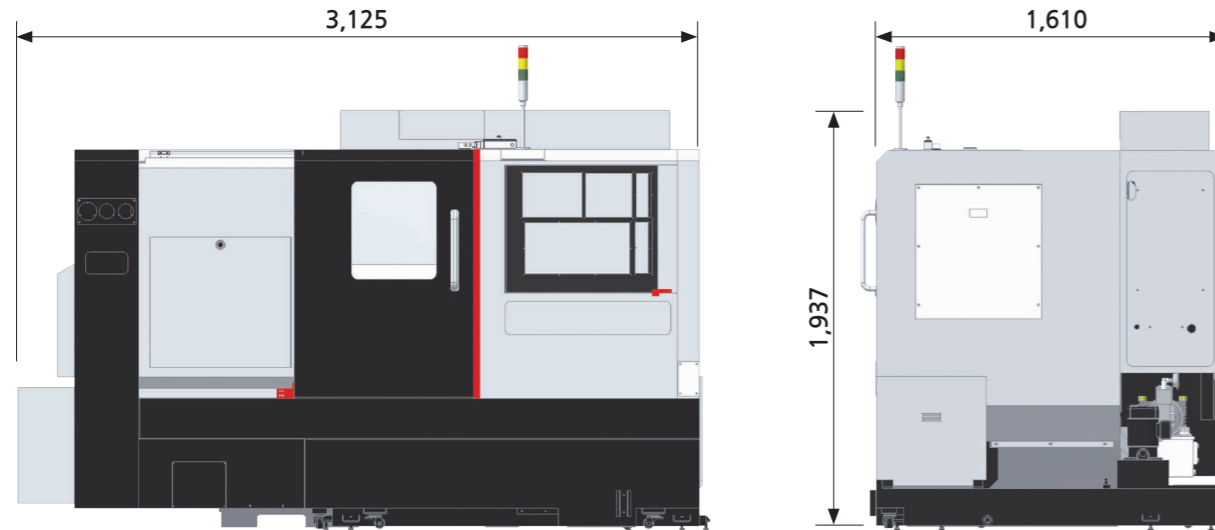

SL 2500X/3000X(2500L/3000L) series

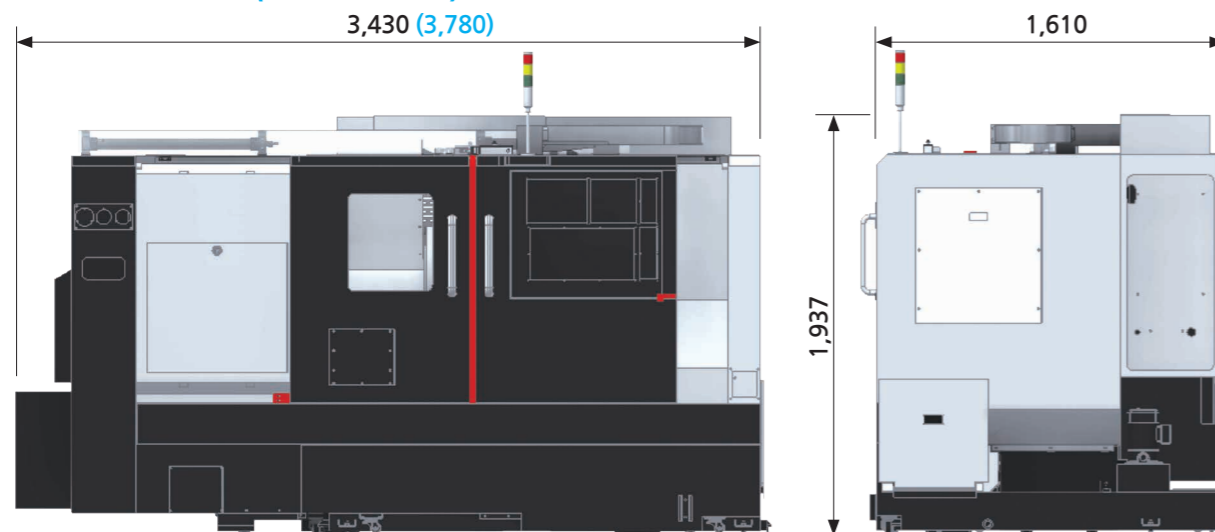

Standard Accessories

- Coolant unit (4.5bar-60Hz)
- Work light (Led lamp)
- Splash guard with side coolant tank
- Tool/Work box
- Hyd. Hollow chuck
8" (SL 2500A/AM)
10" (SL 2500B/BM, SL 3000A/AM)
12" (SL 3000B/BM)
- Soft Jaw 3 sets
- Hard Jaw 1 set
- Leveling unit
- Main spindle orientation
- Chuck clamp foot switch
- Chuck clamp confirmation
- Chuck pressure switch
- Manual/Part list
- Safety precaution name plate
- Door interlock

Optional Accessories

- Side chip conveyor
- Rear chip conveyor with coolant tank
- Chip bucket
- Special chuck
- Dual pressure chucking
- Autodoor with Edge Sensor
- Air gun
- Air blower
- Part catcher
- Oil skimmer
- Chuck coolant
- Shower coolant
- Coolant gun
- Coolant chiller
- 3 step patrol light

Turret Interference

Unit : mm

SL 2500/3000 series

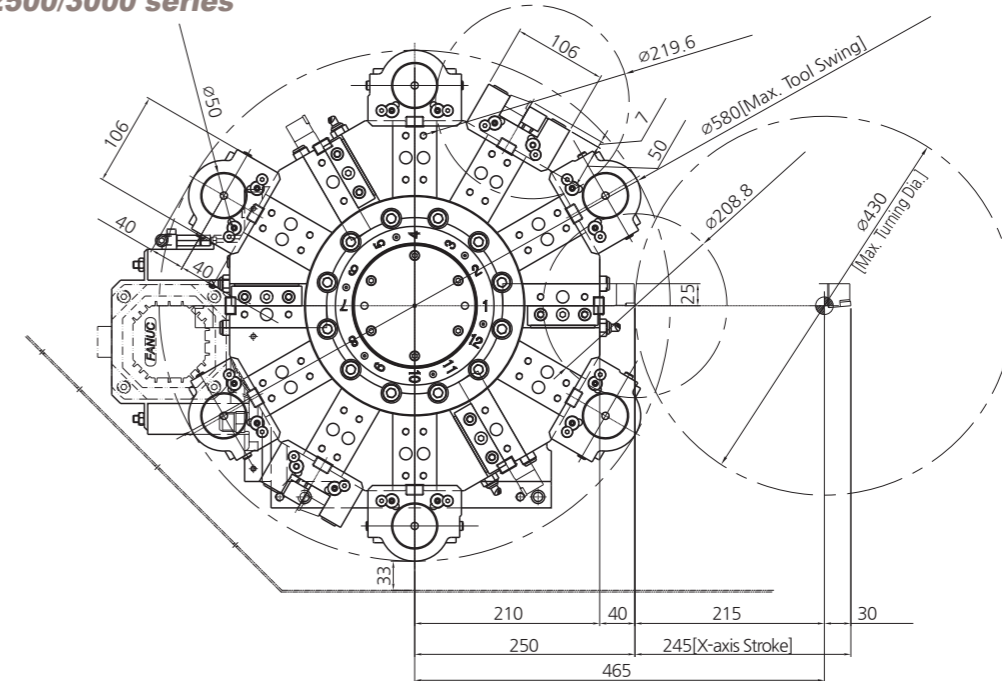

SL 2500M/3000M series

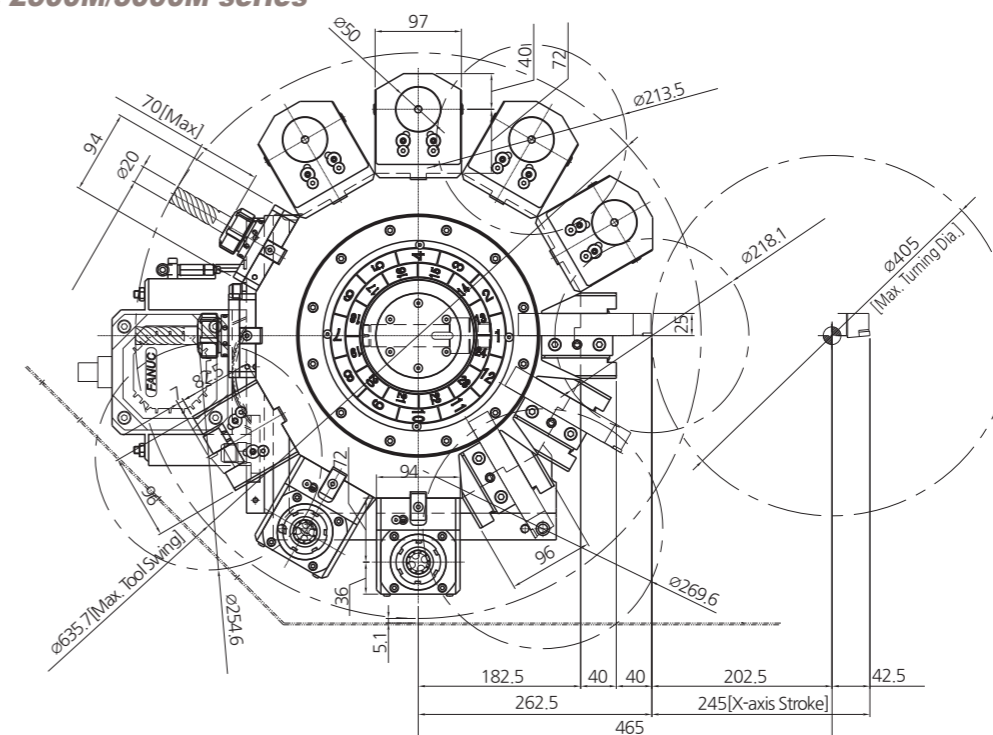

Work Range

Unit : mm

SL 2500/3000 series

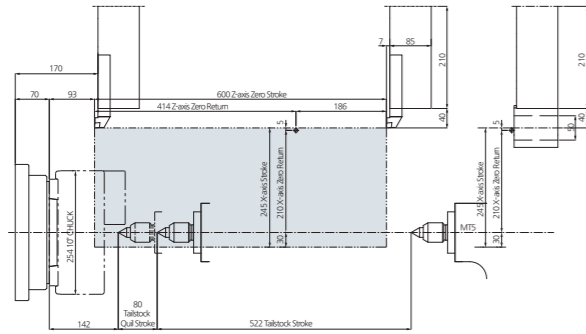

SL 2500M/3000M series

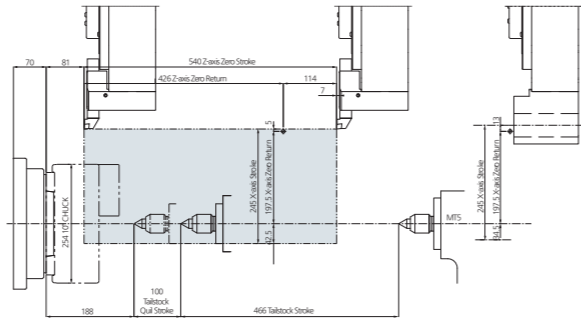

SL 2500X/3000X series

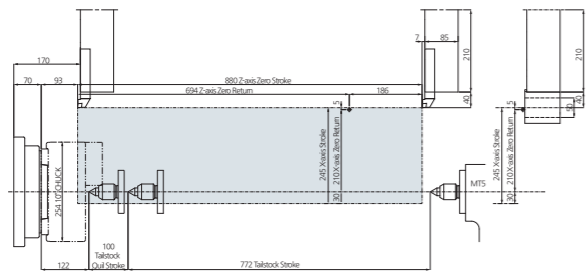

SL 2500XM/3000XM series

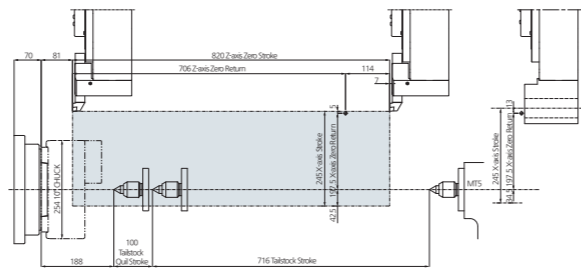

SL 2500L/3000L series

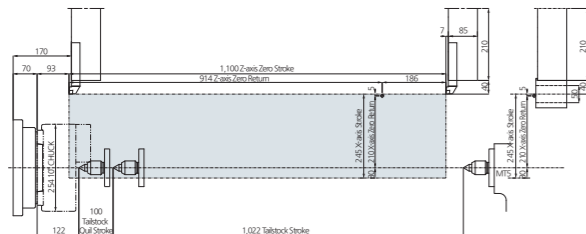

SL 2500LM/3000LM series

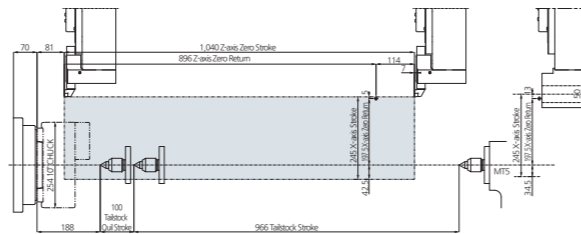

Major Specifications

DESCRIPTION		SL 2500A	SL 2500AM	SL 2500B	SL 2500BM	
Capacity	Swing over the bed	mm	650	650	650	650
	Swing over the cross slide	mm	480	480	480	480
	Max. machining diameter	mm	430	405	430	405
	Max. machining length	mm	570	504	554	497
	Bar working diameter	mm	67	67	76	76
Chuck	Chuck size	inch	8"	8"	10"	10"
	Max. Spindle Speed	rpm	4,500	4,500	3,500	3,500
Spindle	Spindle nose	ASA	A2-6	A2-6	A2-8	A2-8
	Bore diameter	mm	78	78	86	86
	Draw tube I.D.	mm	68	68	77	77
	Motor (Max./Cont.) [OPT.]	kW	18.5/15	18.5/15	18.5/15[26/18.5]	18.5/15[26/18.5]
	X/Z axis travel	mm	245/600	245/540	245/600	245/540
Travel	X/Z rapid traverse rate	m/min	24/30	24/30	24/30	24/30
	X/Z feed motor	kW	3/3	3/3	3/3	3/3
	Number of tool positions [OPT.]	st.	12	12[24](BMT65)	12	12[24](BMT65)
Turret	Indexing time	sec	0.20	0.20	0.20	0.20
	Shank size for square tool	mm	□25x25	□25x25	□25x25	□25x25
	Shank diameter for boring bar	mm	50	50	50	50
	Live tool speed	rpm	-	5,000	-	5,000
Tailstock	Tailstock quill travel (Programmable)	mm	522/85(100)	466/100	522/85(100)	466/100
	Tailstock quill diameter (Programmable)	mm	85(110)	110	85(110)	110
Electric Power Supply	kVA/V	34	34	34(41)	34(41)	
Floor Space(L×W) [With Chip Conveyor]	mm	3,125[4,230]×1,610	3,125[4,230]×1,610	3,125[4,230]×1,610	3,125[4,230]×1,610	
Machine Weight	kg	5,100	5,100	5,100	5,200	
Controller	Fanuc Series					

※ Design and specifications subject to change without notice.

Major Specifications

DESCRIPTION		SL 2500AX	SL 2500AXM	SL 2500BX	SL 2500BXM	
Capacity	Swing over the bed	mm	650	650	650	650
	Swing over the cross slide	mm	480	480	480	480
	Max. machining diameter	mm	430	405	430	405
	Max. machining length	mm	850	784	834	767
	Bar working diameter	mm	67	67	76	76
Chuck	Chuck size	inch	8"	8"	10"	10"
Spindle	Max. Spindle Speed	rpm	4,500	4,500	3,500	3,500
	Spindle nose	ASA	A2-6	A2-6	A2-8	A2-8
	Bore diameter	mm	78	78	86	86
	Draw tube I.D.	mm	68	68	77	77
	Motor (Max./Cont.) [OPT.]	kW	18.5/15	18.5/15	18.5/15[26/18.5]	18.5/15[26/18.5]
Travel	X/Z axis travel	mm	245/880	245/820	245/880	245/820
	X/Z rapid traverse rate	m/min	24/30	24/30	24/30	24/30
	X/Z feed motor	kW	3/3	3/3	3/3	3/3
Turret	Number of tool positions [OPT.]	st.	12	12[24](BMT65)	12	12[24](BMT65)
	Indexing time	sec	0.20	0.20	0.20	0.20
	Shank size for square tool	mm	□25x25	□25x25	□25x25	□25x25
	Shank diameter for boring bar	mm	50	50	50	50
	Live tool speed	rpm	-	5,000	-	5,000
Tailstock	Tailstock quill travel	mm	772/100	716/100	772/100	716/100
	Tailstock quill diameter	mm	100	100	100	100
Electric Power Supply	kVA/V	34	34	34(41)	34(41)	
Floor Space(L×W) [With Chip Conveyor]	mm	3,430[4,535]×1,610	3,430[4,535]×1,610	3,430[4,535]×1,610	3,430[4,535]×1,610	
Machine Weight	kg	5,700	5,700	5,700	5,800	
Controller	Fanuc Series					

※Design and specifications subject to change without notice.

[] : Option

Major Specifications

DESCRIPTION		SL 2500AL	SL 2500ALM	SL 2500BL	SL 2500BLM	
Capacity	Swing over the bed	mm	650	650	650	650
	Swing over the cross slide	mm	480	480	480	480
	Max. machining diameter	mm	430	405	430	405
	Max. machining length	mm	1,070	1,004	1,054	997
	Bar working diameter	mm	67	67	76	76
Chuck	Chuck size	inch	8"	8"	10"	10"
Spindle	Max. Spindle Speed	rpm	4,500	4,500	3,500	3,500
	Spindle nose	ASA	A2-6	A2-6	A2-8	A2-8
	Bore diameter	mm	78	78	86	86
	Draw tube I.D.	mm	68	68	77	77
	Motor (Max./Cont.) [OPT.]	kW	18.5/15	18.5/15	18.5/15[26/18.5]	18.5/15[26/18.5]
Travel	X/Z axis travel	mm	245/1,100	245/1,040	245/1,100	245/1,040
	X/Z rapid traverse rate	m/min	24/30	24/30	24/30	24/30
	X/Z feed motor	kW	3/3	3/3	3/3	3/3
Turret	Number of tool positions [OPT.]	st.	12	12[24](BMT65)	12	12[24](BMT65)
	Indexing time	sec	0.20	0.20	0.20	0.20
	Shank size for square tool	mm	□25x25	□25x25	□25x25	□25x25
	Shank diameter for boring bar	mm	50	50	50	50
	Live tool speed	rpm	-	5,000	-	5,000
Tailstock	Tailstock quill travel	mm	1022/100	966/100	1022/100	966/100
	Tailstock quill diameter	mm	110	110	110	110
Electric Power Supply	kVA/V	34	34	34(41)	34(41)	
Floor Space(L×W) [With Chip Conveyor]	mm	3,780[4,885]×1,610	3,780[4,885]×1,610	3,780[4,885]×1,610	3,780[4,885]×1,610	
Machine Weight	kg	6,300	6,300	6,300	6,400	
Controller	Fanuc Series					

※Design and specifications subject to change without notice.

Major Specifications

DESCRIPTION		SL 3000A	SL 3000AM	SL 3000B	SL 3000BM	
Capacity	Swing over the bed	mm	650	650	650	650
	Swing over the cross slide	mm	480	480	480	480
	Max. machining diameter	mm	430	405	430	405
	Max. machining length	mm	554	497	528	456
	Bar working diameter	mm	76	76	90	90
Chuck	Chuck size	inch	10"	10"	12"	12"
Spindle	Max. Spindle Speed	rpm	3,500	3,500	3,000	3,000
	Spindle nose	ASA	A2-8	A2-8	A2-8	A2-8
	Bore diameter	mm	86	86	105	105
	Draw tube I.D.	mm	77	77	91	91
	Motor (Max./Cont.)	kW	26/18.5	26/18.5	26/18.5	26/18.5
Travel	X/Z axis travel	mm	245/600	245/540	245/600	245/540
	X/Z rapid traverse rate	m/min	24/30	24/30	24/30	24/30
	X/Z feed motor	kW	4/4	4/4	4/4	4/4
Turret	Number of tool positions [OPT.]	st.	12	12[24](BMT65)	12	12[24](BMT65)
	Indexing time	sec	0.20	0.20	0.20	0.20
	Shank size for square tool	mm	□25x25	□25x25	□25x25	□25x25
	Shank diameter for boring bar	mm	50	50	50	50
	Live tool speed	rpm	-	5,000	-	5,000
Tailstock	Tailstock quill travel (Programable)	mm	522/80	466/100	522/80(100)	466/100
	Tailstock quill diameter (Programable)	mm	85	110	85(110)	110
Electric Power Supply	kVA/V	42	42	42	42	
Floor Space(LxW) [With Chip Conveyor]	mm	3,125[4,230]x1,610	3,125[4,230]x1,610	3,125[4,230]x1,610	3,125[4,230]x1,610	
Machine Weight	kg	5,200	5,200	5,200	5,300	
Controller	Fanuc Series					

※Design and specifications subject to change without notice.

Major Specifications

DESCRIPTION		SL 3000AX	SL 3000AXM	SL 3000BX	SL 3000BXM	
Capacity	Swing over the bed	mm	650	650	650	650
	Swing over the cross slide	mm	480	480	480	480
	Max. machining diameter	mm	430	405	430	405
	Max. machining length	mm	834	767	808	736
	Bar working diameter	mm	76	76	90	90
Chuck	Chuck size	inch	10"	10"	12"	12"
Spindle	Max. Spindle Speed	rpm	3,500	3,500	3,000	3,000
	Spindle nose	ASA	A2-8	A2-8	A2-8	A2-8
	Bore diameter	mm	86	86	105	105
	Draw tube I.D.	mm	77	77	91	91
	Motor (Max./Cont.)	kW	26/18.5	26/18.5	26/18.5	26/18.5
Travel	X/Z axis travel	mm	245/880	245/820	245/880	245/820
	X/Z rapid traverse rate	m/min	24/30	24/30	24/30	24/30
	X/Z feed motor	kW	4/4	4/4	4/4	4/4
Turret	Number of tool positions [OPT.]	st.	12	12[24](BMT65)	12	12[24](BMT65)
	Indexing time	sec	0.20	0.20	0.20	0.20
	Shank size for square tool	mm	□25x25	□25x25	□25x25	□25x25
	Shank diameter for boring bar	mm	50	50	50	50
	Live tool speed	rpm	-	5,000	-	5,000
Tailstock	Tailstock quill travel	mm	772/100	716/100	772/100	716/100
	Tailstock quill diameter	mm	110	110	110	110
Electric Power Supply	kVA/V	42	42	42	42	
Floor Space(LxW) [With Chip Conveyor]	mm	3,430[4,535]x1,610	3,430[4,535]x1,610	3,430[4,535]x1,610	3,430[4,535]x1,610	
Machine Weight	kg	5,800	5,800	5,800	5,900	
Controller	Fanuc Series					

※Design and specifications subject to change without notice.

Major Specifications

DESCRIPTION			SL 3000AL	SL 3000ALM	SL 3000BL	SL 3000BLM
Capacity	Swing over the bed	mm	650	650	650	650
	Swing over the cross slide	mm	480	480	480	480
	Max. machining diameter	mm	430	405	430	405
	Max. machining length	mm	1,054	997	1,028	956
	Bar working diameter	mm	76	76	90	90
Chuck	Chuck size	inch	10"	10"	12"	12"
Spindle	Max. Spindle Speed	rpm	3,500	3,500	3,000	3,000
	Spindle nose	ASA	A2-8	A2-8	A2-8	A2-8
	Bore diameter	mm	86	86	105	105
	Draw tube I.D.	mm	77	77	91	91
	Motor (Max./Cont.)	kW	26/18.5	26/18.5	26/18.5	26/18.5
Travel	X/Z axis travel	mm	245/1,100	245/1,040	245/1,100	245/1,040
	X/Z rapid traverse rate	m/min	24/30	24/30	24/30	24/30
	X/Z feed motor	kW	4/4	4/4	4/4	4/4
Turret	Number of tool positions [OPT.]	st.	12	12[24](BMT65)	12	12[24](BMT65)
	Indexing time	sec	0.20	0.20	0.20	0.20
	Shank size for square tool	mm	□25x25	□25x25	□25x25	□25x25
	Shank diameter for boring bar	mm	50	50	50	50
	Live tool speed	rpm	-	5,000	-	5,000
Tailstock	Tailstock quill travel	mm	1,022/100	966/100	1,022/100	966/100
	Tailstock quill diameter	mm	110	110	110	110
Electric Power Supply	kVA/V	42	42	42	42	
Floor Space(LxW) [With Chip Conveyor]	mm	3,780[4,885]x1,610	3,780[4,885]x1,610	3,780[4,885]x1,610	3,780[4,885]x1,610	
Machine Weight	kg	6,400	6,400	6,400	6,500	
Controller	Fanuc Series					

※Design and specifications subject to change without notice.

NC Specifications / Fanuc Series

Item		Description
Controlled axes	Controlled axes	2-axis(X,Z)
	Max. simultaneously controlled axes	Positioning(G00) / Linear Interpolation(G01) Circular Interpolation(G02, G03)
	Least input increment	0.001mm
Spindle function	Spindle speed control	S5 (5 Digit)
	Spindle speed override	50~120%
	Spindle orientation	M19
Feed function	Feedrate override (10% increase)	0~200%
	Dwell	G04
	Reference position return	G27, G28
	Manual pulse generator	0.001/0.01/0.1mm
	Dry run	F0(Fine Feed), 25/50/100%
Tool function	Rapid traverse override	F0(Fine Feed), 25/50/100%
	Tool number command	T2 (2 Digit)
	Tool nose radius compensation	G40 ~ G42
	Tool offset pairs	128EA
Programming function	Tool geometry / wear offset	GEOMETRY & WEAR DATA
	Canned cycle	G70~G72, G74~G76
	Decimal point input	Able to input up to decimal point
	SUB program	4 phase
Tape Functions	Work coordindate system	G52~G59
	Max program dimension	±99999.999mm
	M function	M3 (3 digit)
	Input code	ISO/EIA auto recognition
	I/O interface	RS232C
Other features	Program storage space	1280M(512kb)
	Number of stored programs	400ea
	Display unit / MDI	8.4" color LCD / Soft input type MDI
	Display unit / MDI	10.4" color LCD / Soft input type MDI
	Synchronized tapping	Rigid tapping function
	Background editing	Program saving / editing during automatic operation
	Backlash compensation	Pitch error offset compensation for each axis
	Search function	Sequence / program number search
	Safety function	Emergency stop / overtravel
	Program test function	Machine Lock / Single Block
	Control function	Memory / MDI / Manual
	Mirror image	
	Run hour and parts count display	
Custom macro	#100 ~ #199, #500 ~ #999	