



We lead the way by a new business model



ISO 9001 ISO 14001 2011 TAMI Supreme Excellence Award



HB/HB-F SERIES

WELE MECHATRONIC CO., LTD (<http://www.welegroup.com>)

HEADQUARTERS:
No.458,Shinsing Rd., Hukou Town,Hsin-Chu county 303, Taiwan
TEL : +886-3-696-0360 (rep.) FAX : +886-3-696-0370

TAICHUNG BRANCH:
No.356, Sanfeng Rd., Houli Dist., Taichung City 421, Taiwan
TEL : +886-4-2558-0762 FAX : +886-4-2558-2334

WELE MECHATRONIC (SU-ZHOU) CO., LTD.

No. 8, Ma-Qiao Industrial Block, Chang-Shu Economic
Development Zone, Chang-Shu City, Jiang-Su Province,
215513, China
TEL : +86-512-5229-7868 FAX : +86-512-5229-7866
SALES: 150-5141-3969,150-5141-3981



12091203 MacdS TEL:04-2753326

Horizontal Boring
Machining Center ▶▶▶▶▶



WELE MECHATRONIC CO., LTD

HB1416-110	HB1620-130	AA65 Series RB Series	AA80 Series SB Series	AA90 Series LB Series	AQ Series MB Series	VQ Series HB Series	UG Series UB Series	VTC Series MG Series	MVB Series	MT Series
------------	------------	--------------------------	--------------------------	--------------------------	------------------------	-------------------------------	------------------------	-------------------------	------------	-----------

HB SERIES

Horizontal Boring Machining Center

W Axis and Spindle

WELE provide $\phi 110$ and $\phi 130$ mm, two kind of diameter of W axis which is Max. W axis travel length in the same class product. Gear driven type spindle can be running at 3,500rpm ($\phi 110$ spindle), Max torque of 1188Nm, Rapid traverse(G00) with 5m/min

B axis, Sheet metal of rotary table

Wherever the rotary table at any position, sheet metal can collect chip effectively, keep work zone clean.

B axis, Rotary Table

Outstanding hydrostatic bearing designed and manufactured, are offering the max. load in the same class product. Incremental indexing is 0.001° , rotation angle is 360° continuously, rotation speed is 5 rpm. Patented backlash eliminated mechanism design, increase machining accuracy and long term reliability.

X axis, High Rigidity Bed

Bed is made of the best quality of Meehanite casting, extended the anchor bolt wider, increased the machine stability while the machine is in operation. Long term stable leveling can be secured. Rotary table travel length from 2m to 3m.



Y axis, Vertical Column

Widen column, adapted with linear roller guideway, this design is suitable for precisely machining and heavy cutting. Travel length is 1.8m or 2.1m

Sheet Metal

Convenient for machine maintenance.

Electric Cabinet

Electric cabinet locate nearby operator panel, maintenance will be more easy.

Operator Panel

Using multi rotary joint on operator panel, operator can approach the working envelope, exchange the tool with ease, as well as set up the workpiece and the fixture.

Z axis, Bed

Travel length : 1.3 or 1.5m
G00 X/Y/Z : 15/12/15m/min
Using magnetic scale as close loop feedback system on all axes.



ONLINE SPEC.



ONLINE VIDEO

HB1416-110	HB1620-130	AA65 Series	AA80 Series	AA90 Series	AQ Series	VQ Series	UG Series	VTC Series		
		RB Series	SB Series	LB Series	MB Series	HB Series	UB Series	MG Series	MVB Series	MT Series

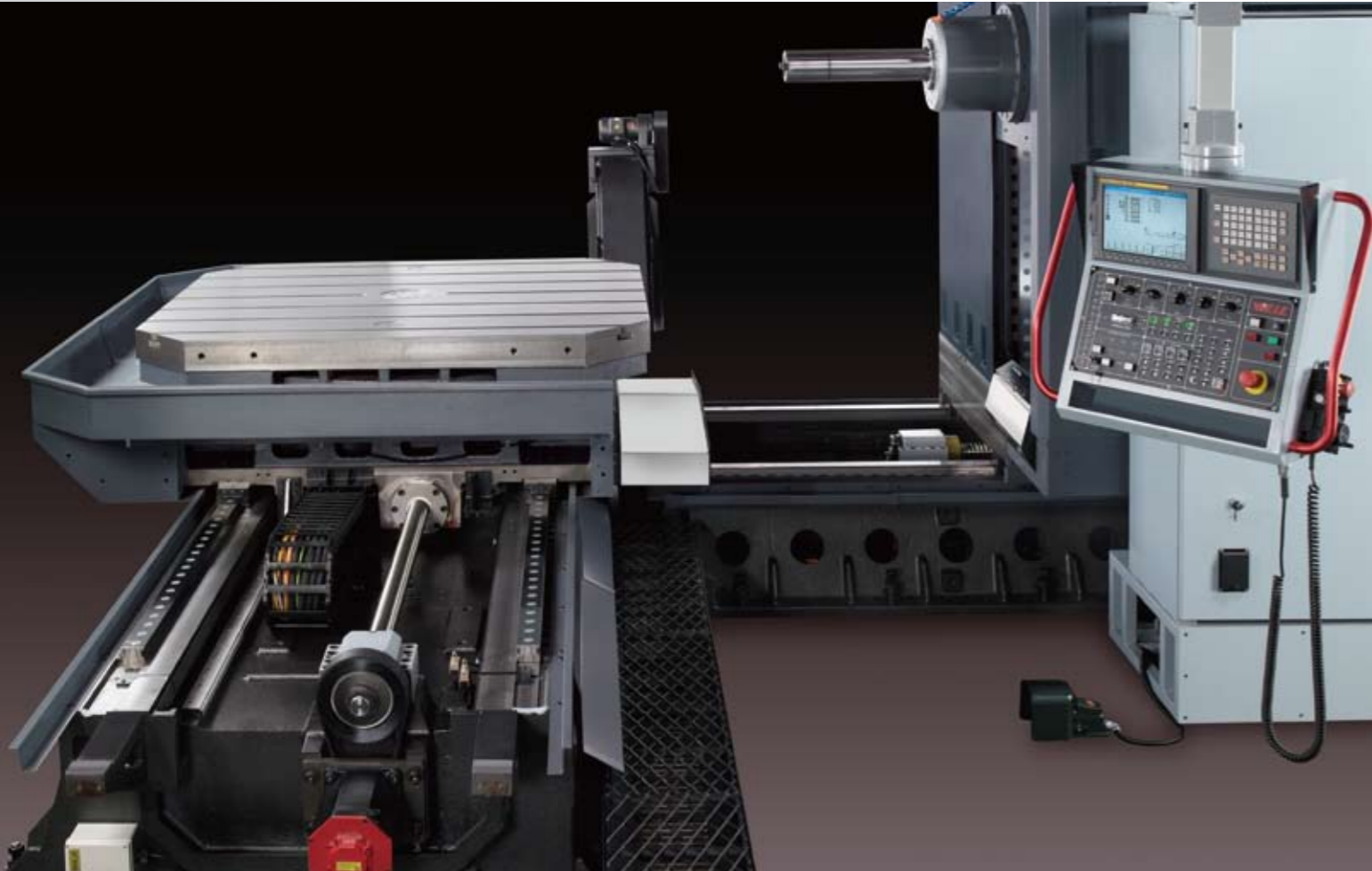

Unique Design in Rotary Table



Rigid construction and Feed system

- Rigid construction and Feed system
- All major parts such as machine bed and column, are made by best quality MEEHANITE casting. To ensure stability of machine.
- Uses ultra heavy load, high accuracy and low friction coefficient with 0.003~0.005 linear roller guide ways provides the high dynamic accuracy, energy consumption at least 40% above can be saving.
- Close loop feedback system is controlling by linear scale on all X/Y/Z/W axes (Optional).
- Provide two kind of W axis travel length, $\varnothing 110\text{mm}$ (travel is 500mm) and $\varnothing 130\text{mm}$ (travel is 700mm), respectively. And spindle max. torque is 1188Nm. These can be used in boring deep hole and counter boring purpose.

Friendly concept design

- Horizontal moveable operator panel locate at right side of column, convenience for user to set up the workpiece and tools. Separately manual hand wheel attaches on operator panel, user can use it to control machine easily.
- The length of caterpillar type chip conveyor is covering the X axial travel length.



Hydro-Static Bearing Design

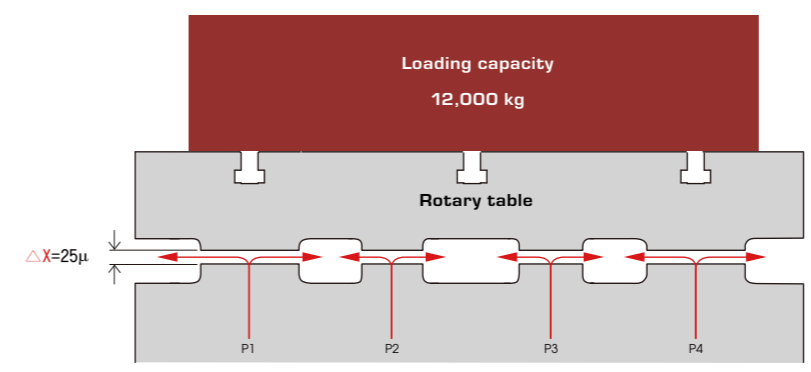

- Special hydrostatic bearing development used in B axis rotary table, achieve high loading machining purpose, max. load is 12 tons [HB1620-130];
- Unique backlash eliminated design bring the machine in high accuracy and reliability. B axis can 360° continuously rotation, incremental index is 0.001°, max. rotation speed is 5 rpm.

Spec.	Unit	HB1416-110	HB1620-130
Size	mm (in)	1440 x 1600 (56.7 x 63)	1600 x 2000 (63 x 78.7)
Load	kg (lb)	8000 (17600)	12000 (26400)
Indexing	degree	0.001 / 5	

Introduce the HB/HB-F series

HB Series-Quill type

Special for deep boring purpose.

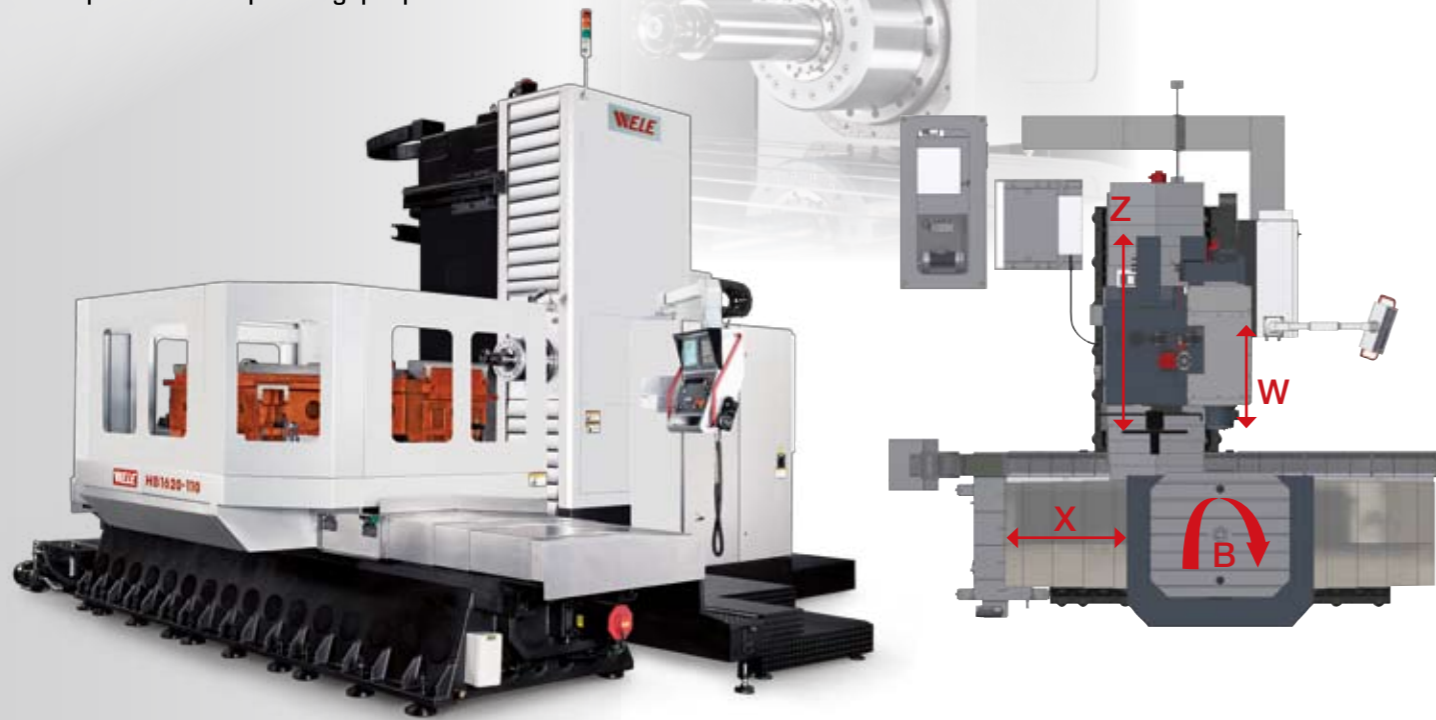

HB-F series-Ram type

Special for ultra-heavy milling purpose

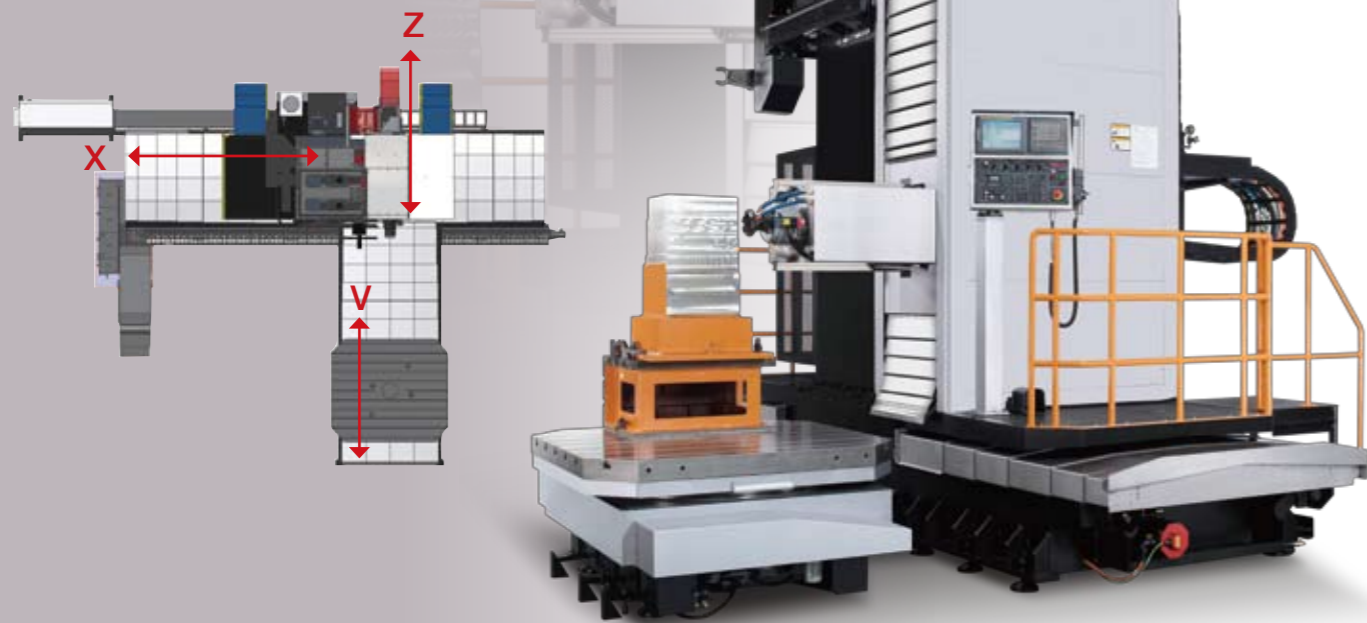

Special Optional Accessories



40 Tools tool Magazine is STD;
60, 90 tools tool magazine are optional available.



Auto tool exchanger(STD.)



Spindle holder(OPT.)



Clamping seat for machining(OPT)



Attach head (OPT)

Item	Specification
Max. output torque	15kW (20HP)
Spindle taper	#50 (BT/DIN/CAT)
Spindle speed	2000rpm
Indexing	45 / 90 degree manually
Attach head exchange	Manual
Tool exchange	Manual

Spindle Output Torque Chart

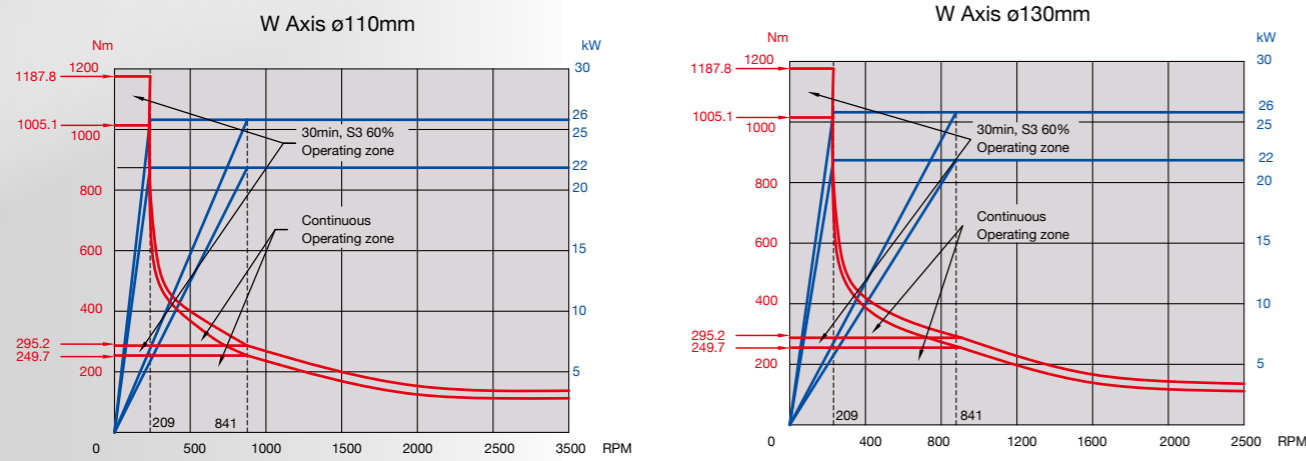

Applications

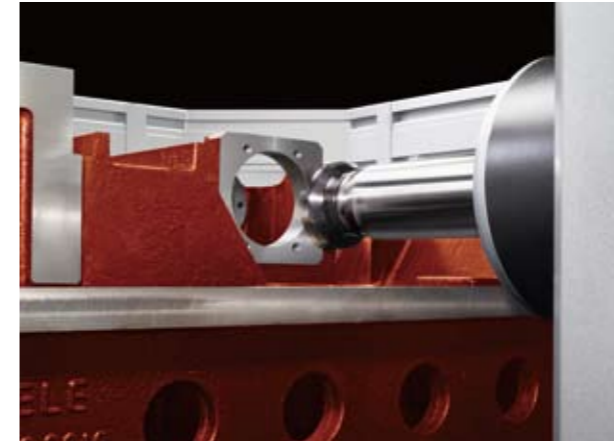

Face Milling

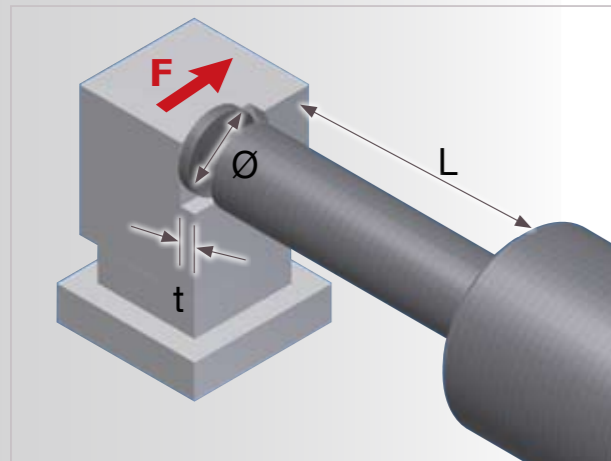

Conditions	HB-1612-130	90 degree head
Face cutter	D125mm	D125mm
W axis elongation (L)	100 mm	640 mm
Cutting width	100 mm	100 mm
Cutting depth (t)	6 mm	4 mm
feedrate	1000 mm/min	1300 mm/min
Material removal	600 c.c/ min	520 c.c/min

Big hole boring, Material: FC30 casting

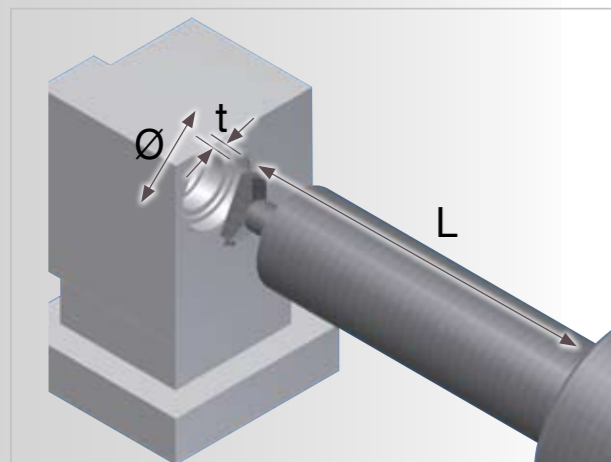

Conditions	HB-1612-130
Boring cutter	D196mm
W axis elongation (L)	100 mm
Cutting width (t)	18 mm (radius)
feedrate	20 mm/min
Material removal	201 c.c/ min



Genius Design and Experience Technology



- Insist on quality.
- Every contact surface all scrapped by excellent skill.
- Unique backlash eliminated mechanism patent be used in rotary table.
- Precisely hydrostatic bearing design on the table, meet the customer requirement of the extra-heavy overload.

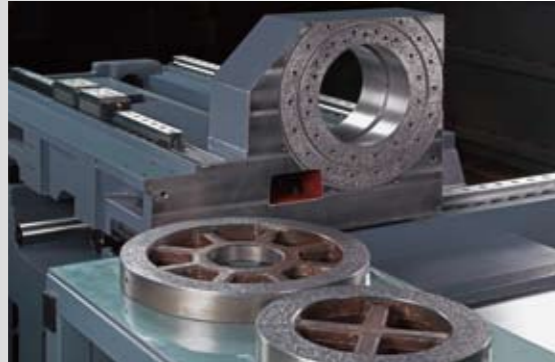

- Every major contact surfaces, are all scrapped by excellent skill. Ensure the geometric accuracy in top level and satisfy customer's quality requirement.

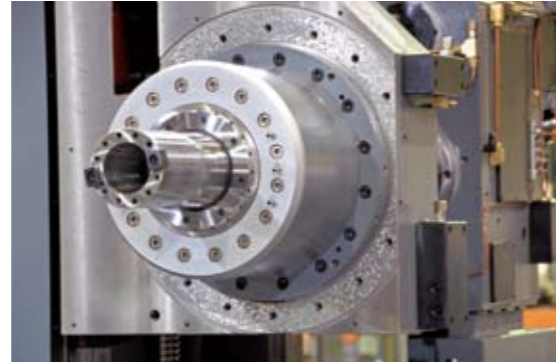

- Unique gear transmission design and excellent scrapping skill guarantee the customers that WELE's horizontal boring machines are the same as Japanese quality level.

Strictly Quality Assurance



Every key components quality assurance was by German WENZEL3D CMM machine.

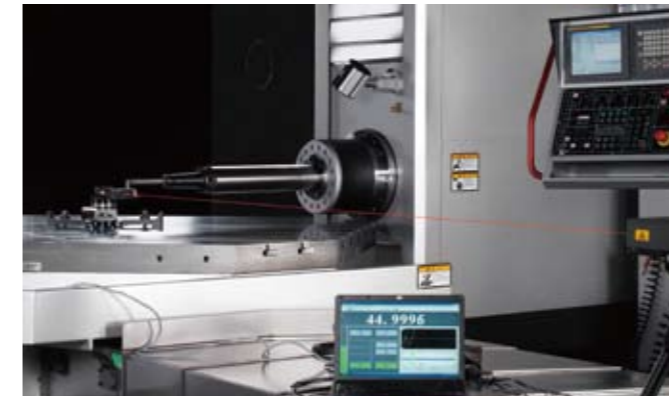

Positioning measurement (VD13441 standard.)



Ball bar Circular interpolation measurement.



NAS test piece approval



Spindle vibration and noise checking.

Technical specifications

Specification	Unit	HB1416-110	HB1620-130
Travel			
X Travel	mm (in)	2000 (78.7)	3000 (118.1)
Y Travel	mm (in)	1800 (70.9)	2100 (82.7)
Z Travel	mm (in)	1300 (51.2)	1500 (59.1)
W Travel	mm (in)	500 (19.7)	700 (27.6)
Distance from spindle nose to table top	mm (in)	200-700 (7.9-27.6)	80-780 (3.1-30.7)
Table			
Table Dimension	mm (in)	1600 x 1440 (63.0 x 56.7)	2000 x 1600 (78.7 x 63.0)
Table Indexing positioning accuracy	degree	0.001	0.001
Table load capacity	kg (lb)	8000 (17,637.0)	12000 (26,455.5)
Table T slot size (W x distance x number)	mm (in)	24x200x7 (0.9x7.9x7)	24x200x9 (0.9x7.9x9)
Spindle			
Spindle motor (cont./30min. rating)	kW (HP)	22/26 (30/35)	
Spindle speed (Two steps geared)	rpm	1~3500	1~2500
Spindle torque (cont./30min. rating)	Nm (ft-lb)	1005/1187.8 (740.4/876.1)	
Spindle taper		BT#50	
Feedrate			
Rapid traverse rate (X/Z axis)	mm (in)/min	15000 (590.6)	
Rapid traverse rate (Y axis)	mm (in)/min	12000 (472.4)	
Rapid traverse rate (W axis)	mm (in)/min	5000 (196.9)	
Rapid traverse rate (B axis)	rpm	5	
Cutting feedrate (max.)	mm (in)/min	1-5000 (0.04-196.9)	
Axes guideways		Linear Roller Guideway	
Tool magazine			
Tool magazine capacity	pockets	40	
Max. tool diameter / adjacent pocket empty	mm (in)	125/250 (4.9/9.8)	
Max. tool length (from gauge line)	mm (in)	400 (15.7)	
Max. tool weight	kg (lb)	25 (55.1)	
Accuracy			
Positioning accuracy (JIS 6338)	mm (in)	±0.022 (0.0009) full travel	
Positioning accuracy (VDI 3441)	mm (in)	P ≤ 0.016 (0.0006)	P ≤ 0.020 (0.0008)
Repeatability accuracy (JIS 6338)	mm (in)	±0.010 (0.0004)	
Repeatability accuracy (VDI 3441)	mm (in)	Ps ≤ 0.012 (0.0005)	Ps ≤ 0.015 (0.0006)
Space requirement & weight			
Machine length	mm (in)	6500 (255.9)	7500 (295.3)
Machine width	mm (in)	6292 (247.7)	6692 (263.5)
Machine height	mm (in)	4136 (162.8)	4436 (174.6)
Machine weight	kg (lb)	30000 (66,138.7)	35000 (77,161.8)
Others			
Total required power (AC220V ± 10%, 3 Phase, 60 Hz/50Hz)	kVA	65	
Pneumatic pressure requirement	kg/cm ²	5	

**Product specifications and accessories are subject to change without notice.

**Specially order like HB1620-160, HB1620-200, HB-xxxF etc. are also available on request.

Standard and optional accessories

● : Standard ○ : Option

Specification/ Model	HB1416-110	HB1620-130
BT50 spindle taper+MAS pull stud	●	●
DIN50 spindle taper	○	○
CAT50 spindle taper+ANSI pull stud	○	○
Spindle (30/35HP)	●: 3500 rpm	●: 2500 rpm
Spindle & gearbox temperature controll system	●	●
Adjustable torque-limit clutch (3 axes)	●	●
X Travel extend to 2,000 mm (78.7")	●	○
X Travel extend to 3,000 mm (118.1")	○	●
Centralized automatic lubrication system	●	●
Semi-full splash guarding sheet metal	○	○
Flood coolant system (Pump & tank)	●	●
Recycling lubrication oil collector for 3 axes	●	●
Caterpillar type chip conveyor	●	●
40 tools capacity of tool magazine	●	●
60 tools capacity of tool magazine	○	○
90 tools capacity of tool magazine	○	○
Rigid tapping	●	●
Footswitch for tool clamping	●	●
Remote handwheel control	●	●
Work light	●	●
Operation cycle finish and alarm lights	●	●
RS232 interface	●	●
Spray hose for chip wash down	●	●
Electric cabinet and heat exchanger	●	●
Air conditioner instead of Heat exchanger	○	○
Oil skimmer	○	○
Foundation bolt kit	●	●
Machine manuals	●	●
Linear scale feedback system for X/Y/Z	●	●
Coolant through the tool adapter	○	○
Coolant through the spindle (Form A) w/1000 liter tank	○	○
Swing type operator panel (moveable in horizontal direction)	●	●
FANUC 31iM Controller	●	●

**Product specifications and accessories are subject to change without notice.

**Specially order like HB1620-160, HB1620-200, HB-xxxF etc. are also available on request.