

PALMARY PCB-3010



Tipo: Rettifica senza centri Senza centri CNC

Brand: PALMARY

Modello: PCB-3010

C.N.C: FANUC

Specifiche:

A CUSCINETTI

Informazioni tecniche

CAPACITÀ

Ø rettificabile: 0-25 mm

DETTAGLI

Ø mola conduttrice x larghezza/alesaggio: 305x100x177.8 mm

Ø Mola condotta x larghezza/alesaggio: 205x100x90 mm

Potenza mandrino rettificazione: 3.7 kw

Velocità rotazione: 45 m/s mt/min

Peso: 2100 kg



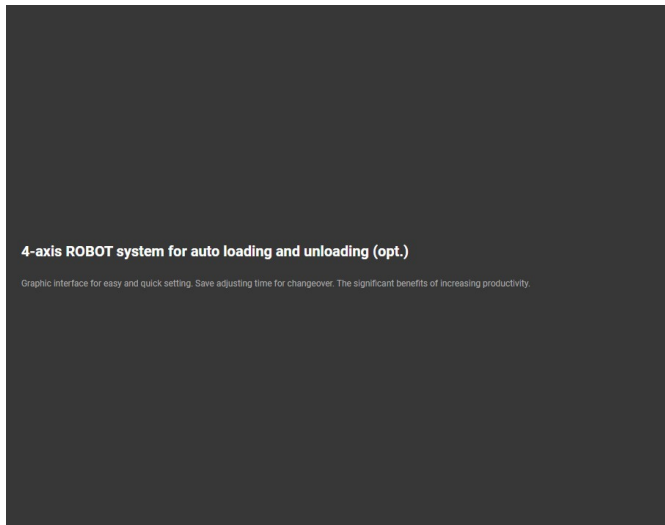

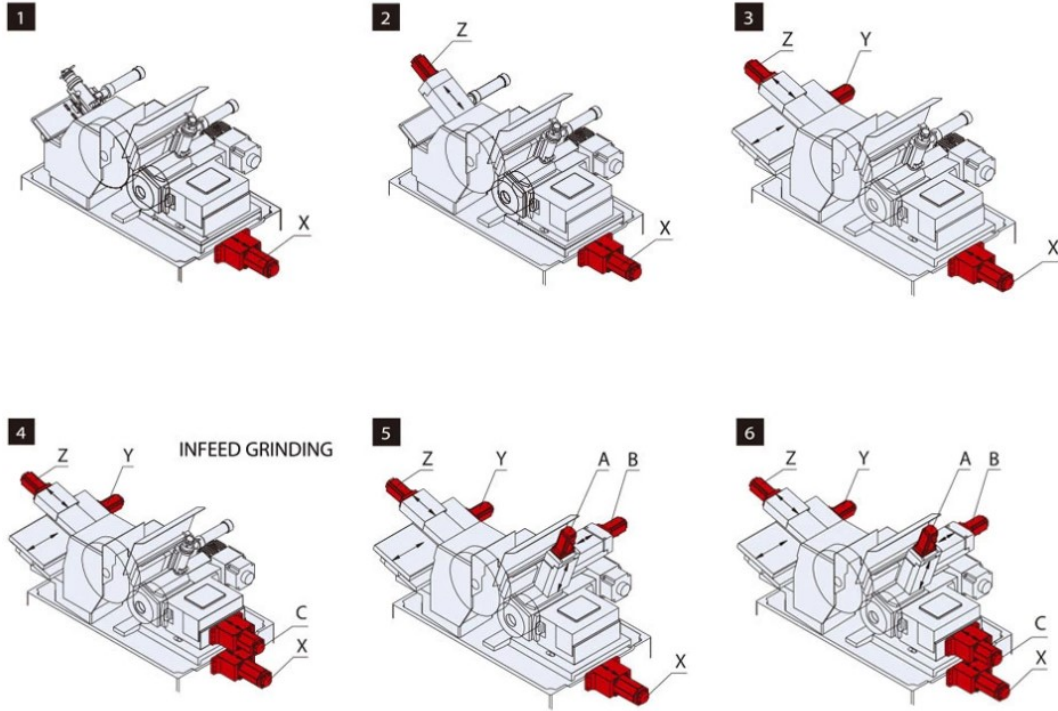

Spindle included high precision duplex roller bearing

High rigidity single supporting design to accomplish high precision and stability of grinding job.

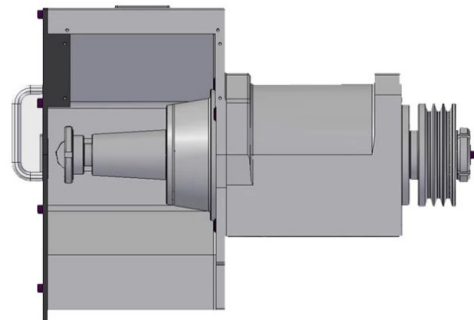



Model	PCB-3010
Grinding Wheel	
Standard grinding range (dia.)	Ø0.3~Ø25 mm
Grinding wheel size (O.D. x width x I.D.)	Ø305 x 100 x Ø177.8 mm
Linear velocity	45 M/s
Dressing device	Single-point dressing device / (opt.) Diamond roller dressing device
Regulating Wheel	
Regulating wheel size (O.D. x width x I.D.)	Ø205 x 100 x Ø90 mm
Regulating wheel speed	10~200 r.p.m. (variable speed)
Regulating wheel tilt angle	± 5°
Regulating wheel swivel angle	±0.5°
Regulating wheel dressing device swivel angle	±5°
Dressing device OFFSET	0~5 mm
Slider	
Lower and upper slider	Square slider, Ball screw + reducer
Motor	
Grinding wheel	3.7 kW
Regulating wheel	0.75 kW
Coolant pump	0.093 kW (wheel cooling) / 0.093 kW (dressing cooling)
Lubrication	
G.W. lubrication	Oil mist type
R.W. lubrication	Oil grease type
Lubrication	Auto lubricator (LUBE)
Controller	
Brand	FANUC
Tank	
Coolant tank	100 L
Grinding wheel spindle lubrication system	1.0 L
Table slide lubrication	4.0 L
Weight	
New weight	2100 kg